

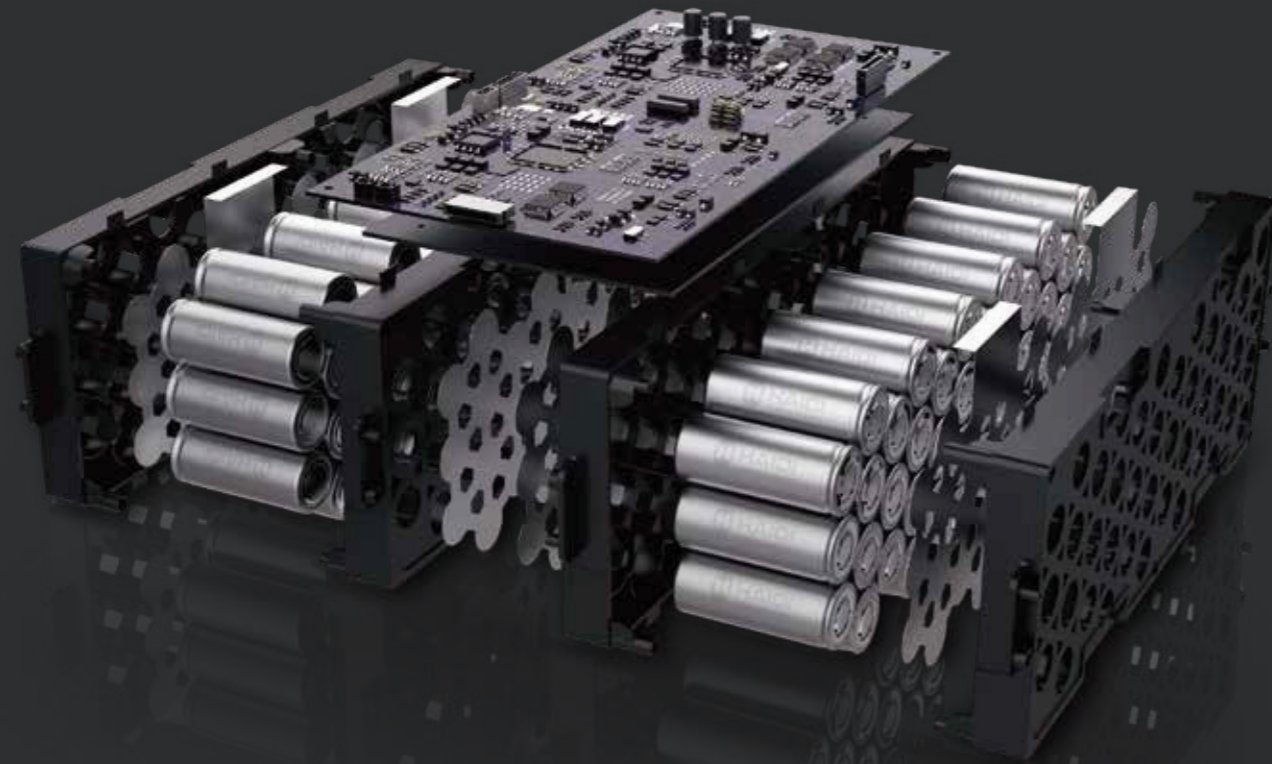

YOUR TRUSTED **POWER** OF CHOICE

Advanced Lithium Battery Solutions



www.haidienergy.com





CONTENTS

- 01** ABOUT HAIDI
- 02** LITHIUM-ION CELLS
- 03** LIFEPO4 CELLS
- 04** PHOSPHATE PRISMATIC CELL
- 05** BATTERY MODULES
- 06** SEALED LEAD ACID REPLACEMENT
- 07** POWER TOOL BATTERIES
- 08** EMERGENCY LIGHT BATTERIES
- 09** SOLAR STREET LAMP BATTERIES
- 10** ENERGY STORAGE SYSTEM
- 11** ELECTRIC VEHICLE BATTERIES

about

our company

Ideal Partner for Your Sustainability Journey

As the global population grows, humanity is putting increased pressure on the planet, changing the climate, depleting resources and polluting the environment.

Haidi is the ideal partner for customers on their sustainability journey. Our Lithium battery products, systems, solutions and services improve energy and resource efficiency, facilitate the transition towards renewable and decentralized power generation, while ensuring resilient and reliable power supply.

Create a Better Tomorrow

The answers to the challenges of our time matter – for the quality of life of people today and generations to come. Haidi is committed to provide answers for a better future, answers to lay the foundation for societies to thrive and for people to be empowered. We empower our customers to transform the backbone of our industries and economies, by developing sustainable stored energy technologies to make manufacturing cleaner, infrastructure more energy efficient, provide access to clean energy, transit smarter and healthier for the planet. Sustainability is an integral part of our business – it's in our DNA.



50+

Distributors Worldwide

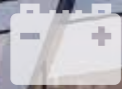

1000+

Battery Solutions



100+

Patents



200,000m²

Production Space

* Photo taken from Haidi production line
© All rights reserved.

OUR MISSION

To ensure our customers' long-term profitability by providing safer and higher energy density battery which benefit sustainability to our world and shape human's new life in the future. Pushing limit of battery energy density without comprising the safety and cycle life is our ongoing mission.

OUR VISION

We contribute in reducing the world's environmental issues encouraging electrification across all industries, by developing battery technology that facilitates more eco-friendly means of transportation and energy storage system.

POWER BEYOND BELIEF

ABOUT

Engineering Excellence

We invest major efforts and resources in new product development so we can help our customers meet their long-term energy goals. When it comes to innovation, we have the sharpest minds in the business designing, building and testing our products. We invest in people with the industry experience, training and relationships to ensure our customers' success.

Leading Technology

Our advanced R&D team constantly strives for higher energy density cells that operate across a wide temperature range and offer long cycle life.

With accumulated extensive expertise and knowhow, valuable database and design, validation methodologies over the past 10 years in chemical research and manufacturing. Our team play a central role in driving advanced technology forward on time and with good value.

Working with us, customers are bringing future products in market as leading position.

Invested in Our Future, And Yours

We're dedicated to providing clean, green reliable power for a variety of applications. When you're looking for a trustworthy partner to build your custom product, let our experts reduce development risk and bring a high-quality product to market faster for you. Whatever your energy needs, we're ready to meet the demand.

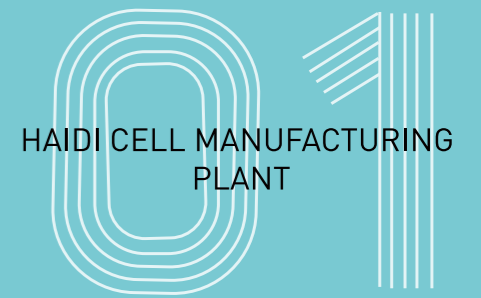

HAI DI CELL MANUFACTURING PLANT



HAI DI BATTERY PACK ASSEMBLY FACTORY

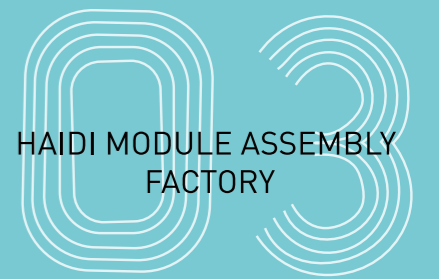

HAI DI MODULE ASSEMBLY FACTORY



HAI DI INNOVATION CENTER

ABOUT HAIDI

Global Leading Lithium Battery Manufacturer

At Haidi, we have a powerful story to tell - a history of great achievements, world class talent, and innovative breakthroughs. Most importantly, we have a history of working with our customers to develop a deep understanding of their unique applications and requirements. Our research & engineering team uses this knowledge to design and manufacture purpose-built NMC, NCA, LiFePO4 cylindrical and prismatic cells and stored energy solutions to meet our customers' needs.

-2005, Haidi built one of the first "Lithium Battery Cell R&D Lab" in China, ever since then, company is incubating new technologies, the Haidi team continue breaking new frontiers in science and engineering, and keeping improving the safety, performance and lifespan of NMC, NCA and LiFePO4 battery cells.

-2007, Haidi launched one of worldwide first LiFePO4 battery cells production line, we are proud to contribute to Lithium battery industry by bringing LiFePO4 battery Cells into serial production.

-2009, Haidi is worldwide first company to bring LiFePO4 batteries into maritime applications. Haidi's LiFePO4 batteries has been installed in the research vessel of CSIC.

-2020, Haidi developed first automatic zero-waste and zero-pollution lithium-ion battery recycle line. Haidi obtains 6 patents for this unique technology.

-By Dec.2021, Haidi obtains 270 patents in battery cell chemistry, design and production.

Haidi is at the forefront of innovation, with the expertise and agility to move at the speed of today's businesses. At Haidi, the customer comes first, and everything we do must be put through that filter. In terms of the Safety, Energy Density, Lifespan, C-Rate, and Working Temperature Range, Haidi delivers the "best in class" battery cells to the global customers, specially in LiFePO4 cells technology. For instant, In 2021 Haidi was the first company in the position to serial produce 26650 LFP cells with 5000mAh(1C/3C).

Haidi Energy is certified with ISO9001, ISO14001, IATF16949 and OHSAS18001 management systems. Our products have obtained UL, CE, IEC62133, KC, BIS, ROHS, UN38.3, MSDS certificates, additionally all of our products are protected by the worldwide product liability insurance.

Haidi leads the industry in the research, design, manufacturing, and distribution of leading-edge Lithium battery technologies to the transportation, motive power, maritime and energy storage industries. We are developing new technologies and delivering enhanced solutions for applications where performance and productivity matter. Innovation and performance are at the centre of our companies. We have an unwavering commitment to help our customers succeed.

TIMELINE

COMPANY HISTORY

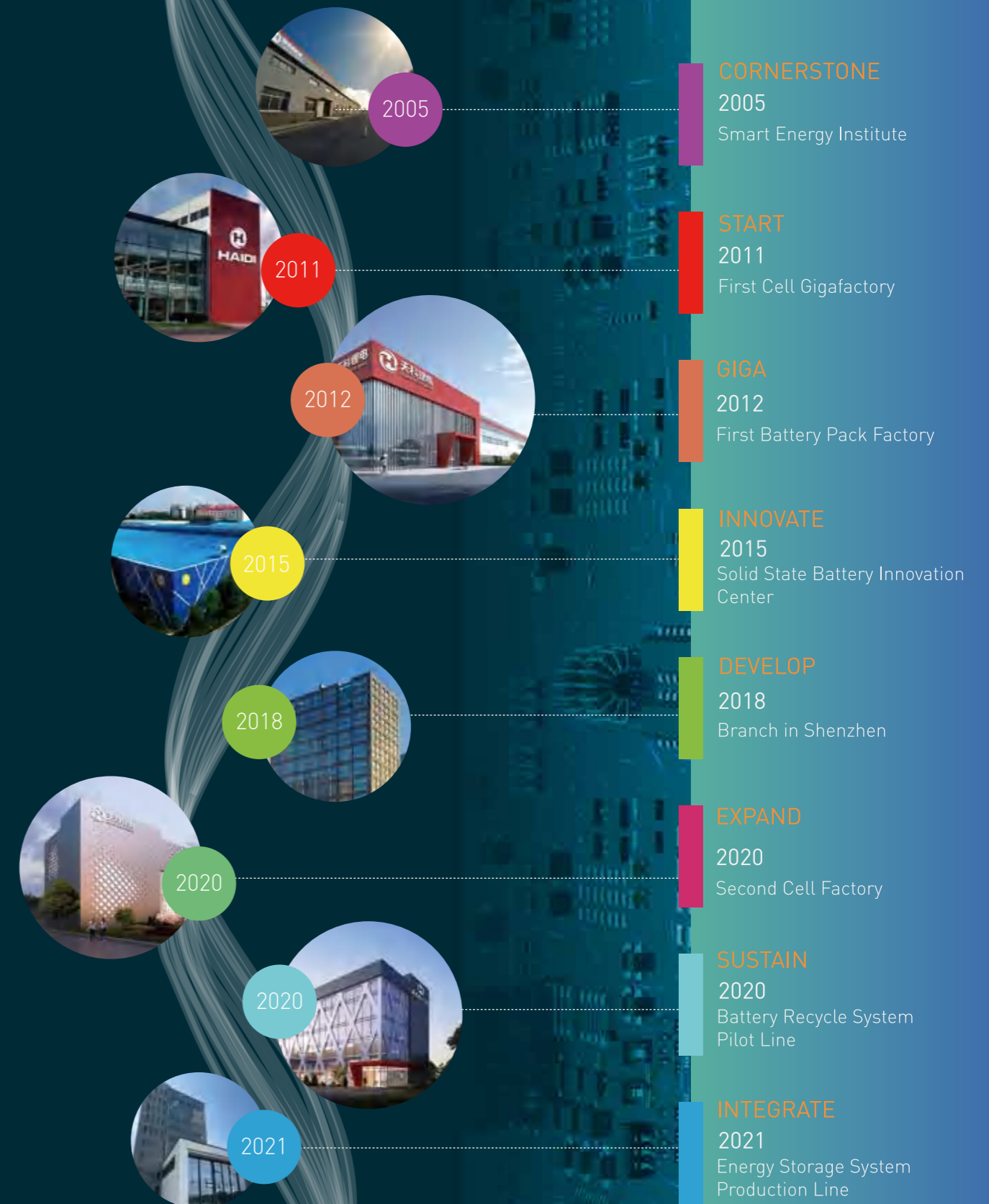

WHY CHOOSE US

Haidi Cell for Next Generation Products in Field

Push-to-the-Limit



“ We're here to take care of every need, from the second you contact us. ”

Besides our regular production category of cells and packs, we can also provide:

- * Design and assembly for all battery chemistries
- * Battery assembly service in China, Slovenia, Thailand and India.
- * UN, UL & IEC testing and certification application
- * Large engineering department and testing lab service
- * State-of-the-art production facilities

Outstanding cell is the key to drive revolution development in applications.

High-power cell

Up to 260Wh/kg

Electrode

Ultra-3D connecting network

Electrolyte system

Reduced resistance between electrodes

High safety separator

Low resistance and high porosity

Anode material

Advanced graphene coating technology

Cathode material

Patented material compositions

Lithium-ion Cells

NCM&NCA CHEMISTRY

LITHIUM-ION A perfect combination of high energy density (e.g. NCM&NCA technology), safety (PTC device) and long-life shows what is possible with Lithium-Ion battery technology from Haidi Energy. Excellent battery safety on one hand, and superior battery performance on the other: this is what Haidi stands for.



Part Number	Nominal Voltage	Rated Capacity	Internal Resistance	Discharge Rate	Dimension(mm)		Weight(g)	Energy Density Gravimetric(Wh/Kg)
					Diameter	Height		
HDCNR18650-1500-3.7V	3.7V	1500mAh	≤15mΩ	15C	18.15±0.1	65.0±0.15	43.0	129
HDCNR18650-2000-3.7V	3.7V	2000mAh	≤15mΩ	5C	18.15±0.1	65.2±0.30	44.0	168
HDCNR18650-2000-3.7V	3.7V	2000mAh	≤15mΩ	10C	18.20±0.1	65.3±0.30	45.0	164
HDCNR18650-2200-3.7V	3.7V	2200mAh	≤15mΩ	5C	18.15±0.1	65.3±0.30	47.0	173
HDCNR18650-2500-3.7V	3.7V	2500mAh	≤20mΩ	8C	18.15±0.1	65.3±0.30	48.0	200
HDCNR18650-2600-3.7V	3.7V	2600mAh	≤20mΩ	5C	18.15±0.1	65.3±0.30	48.0	200
HDCNR18650-3000-3.7V	3.7V	3000mAh	≤35mΩ	3C	18.15±0.1	65.3±0.20	48.0	163
HDCNR18650-3200-3.7V	3.7V	3200mAh	≤35mΩ	1C	18.50±0.1	65.3±0.20	48.0	173
HDCNR21700-4000-3.7V	3.7V	4000mAh	≤17mΩ	3C	21.60±0.1	71.0±0.20	69.0	214
HDCNR21700-5000-3.7V	3.7V	5000mAh	≤15mΩ	3C	21.60±0.1	71.0±0.20	88.0	210
HDCNR26650-4500-3.7V	3.7V	4500mAh	≤30mΩ	3C	26.50±0.1	65.5±0.20	90.0	185
HDCNR26650-5000-3.7V	3.7V	5000mAh	≤30mΩ	3C	26.5±0.1	65.5±0.20	90.0	205

SAFETY GUARANTEE

Using 2 built-in safety additions, Haidi Energy ensures an explosion proof structure for its cylindrical lithium batteries, and a power cut off in case of overload.

- ① Positive pole
- ② PTC (Positive Temperature Coefficient Device optional)
- ③ Collector
- ④ Cell can
- ⑤ Cathode (Manganese Dioxide)
- ⑥ Negative pole
- ⑦ Insulator
- ⑧ Anode (Lithium)
- ⑨ Separator
- ⑩ Tube
- ⑪ Vent diaphragm

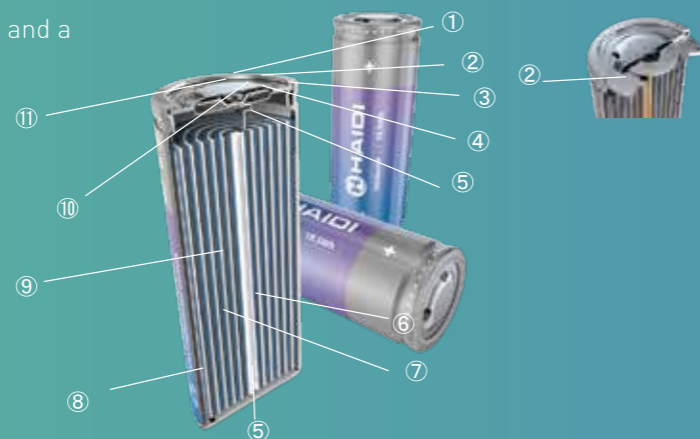

OUTSTANDING SPECIFIC POWER

EXCELLENT PERFORMANCE IN EXTREME TEMPERATURES

Thanks to the unique composition of Haidi Energy's patented lithium iron phosphate materials, this battery is able to function in extreme temperatures (-20°C to +65°C) without hesitance.

HIGH POWER DENSITY



5C

Discharge Rate=13A 5C Rating

High Discharge 5C Rating 18650 Cell

2600 mAh

HDCNR18650-2600mAh-3.7V

- Utilizing a higher charge acceptance
- Delivering outstanding discharging current
- Dual coeuctor tabs design
- Extremely low internal resistance

8C

Discharge Rate=30A 8C HIGH DISCHARGE RATE

High Discharge 8C Rating 18650 Cell

2500 mAh

HDCNR18650-2500mAh-3.7V

- Ultra safety
- Industry-leading cycle Life
- wide operating temperature range
- Flame Retardant Housing

Lithium Iron Phosphate Cells

LiFePO4 CHEMISTRY

Haidi's Phosphate based technology possesses superior thermal and chemical stability which provides better safety characteristics than those of Lithium-ion technology made with other cathode materials. Haidi Lithium Iron Phosphate cells are incombustible in the event of mishandling during charge or discharge, they are more stable under overcharge or short circuit conditions and they can withstand high temperatures without decomposing. When abuse does occur, the phosphate based cathode material will not burn and is not prone to thermal runaway.



- ULTRA SAFETY
- PREMIUM QUALITY
- PROLONGED CYCLE LIFE
- ULTRA-LIGHT
- LOW CONSUMPTION
- HIGH ENERGY DENSITY

Part Number	Nominal Voltage	Rated Capacity	Internal Resistance	Discharge Rate	Dimension(mm)		Weight(g)	Energy Density Gravimetric(Wh/Kg)
					Diameter	Height		
HDCF18650-1500-3.2V	3.2V	1500mAh	≤30mΩ	3C	18.2±0.2	65.3±0.3	41.0	117
HDCF18650-1600-3.2V	3.2V	1600mAh	≤30mΩ	3C	18.2±0.2	65.3±0.3	41.0	124
HDCF18650-1800-3.2V	3.2V	1800mAh	≤30mΩ	3C	18.2±0.2	65.3±0.3	42.0	137
HDCF18650-2000-3.2V	3.2V	2000mAh	≤30mΩ	3C	18.2±0.2	65.3±0.3	44.0	145
HDCF26650-2000-3.2V	3.2V	2000mAh	≤25mΩ	3C	26.2±0.2	65.3±0.3	58.0	110
HDPF26650-2100-3.2V	3.2V	2100mAh	≤25mΩ	3C	26.2±0.2	65.5±0.2	59.0	113
HDPF26650-2200-3.2V	3.2V	2200mAh	≤25mΩ	3C	26.2±0.2	65.5±0.2	59.0	119
HDPF26650-2400-3.2V	3.2V	2400mAh	≤32mΩ	3C	26.2±0.2	65.5±0.2	79.0	97
HDPF26650-2800-3.2V	3.2V	2800mAh	≤32mΩ	3C	26.2±0.2	65.5±0.2	82.0	109
HDPF26650-3000-3.2V	3.2V	3000mAh	≤10mΩ	10C	26.2±0.2	65.5±0.2	87.0	110
HDCF26650-3200-3.2V	3.2V	3200mAh	≤20mΩ	3C	26.2±0.2	65.5±0.2	85.0	120
HDCF26650-3300-3.2V	3.2V	3300mAh	≤20mΩ	3C	26.2±0.2	65.5±0.2	85.0	124
HDCF26650-3400-3.2V	3.2V	3400mAh	≤20mΩ	3C	26.2±0.2	65.5±0.2	85.0	128
HDCF26650-3600-3.2V	3.2V	3600mAh	≤20mΩ	3C	26.2±0.2	65.5±0.2	87.0	132
HDCF26650-3800-3.2V	3.2V	3800mAh	≤20mΩ	3C	26.2±0.2	65.5±0.2	89.0	136
HDCF26650-4000-3.2V	3.2V	4000mAh	≤20mΩ	3C	26.2±0.2	65.5±0.2	89.0	143
HDCF26650-4200-3.2V	3.2V	4200mAh	≤20mΩ	3C	26.2±0.2	65.5±0.2	93.0	144
HDCF26650-4500-3.2V	3.2V	4500mAh	≤25mΩ	3C	26.2±0.2	65.5±0.2	95.0	144

Unrivalled Power Density

HIGH ENERGY DENSITY

In addition to a multitude of cell sizes, Haidi Energy offers a range of cylindrical cells derivatives to address specific and unique performance requirements including specific energy, specific power, safety, performance, lifespan, and cost.

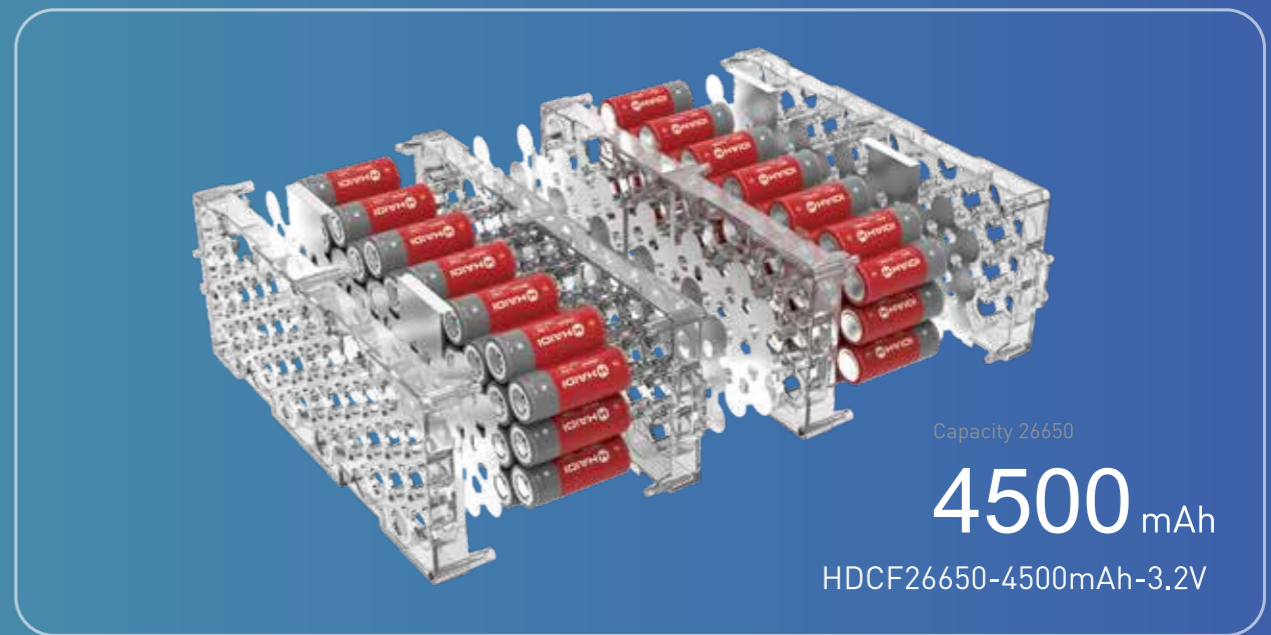

PUSH-TO-THE-LIMIT

Model number (examples)

HDCNR-18650-2600-3.7V

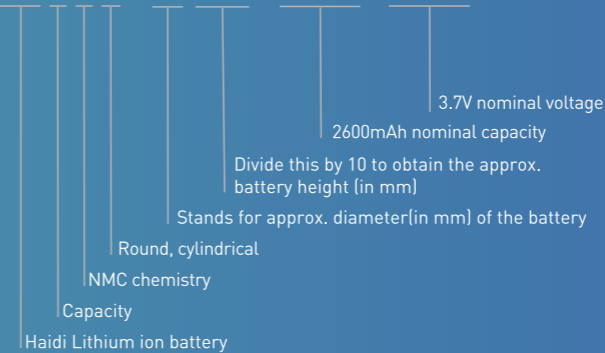

HDCF26650-4500-3.2V Cycle Chart (0.5C)

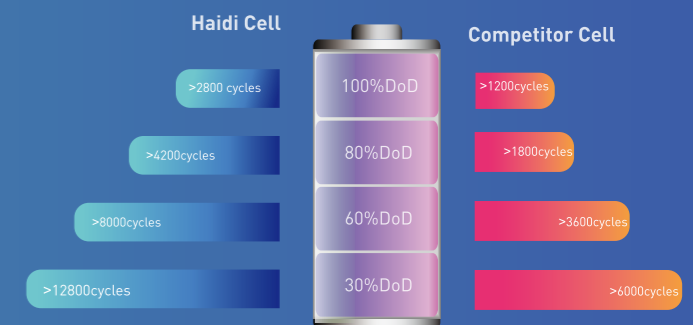

HAIIDI



High Discharge Rate-30C

30C

Discharge Rate

1100^{mAh}

Nominal Capacity

33A

Continuous Current

Bipolar lugs have strong electric conductivity, fast speed and small internal resistance, so they are suitable for High power batteries.

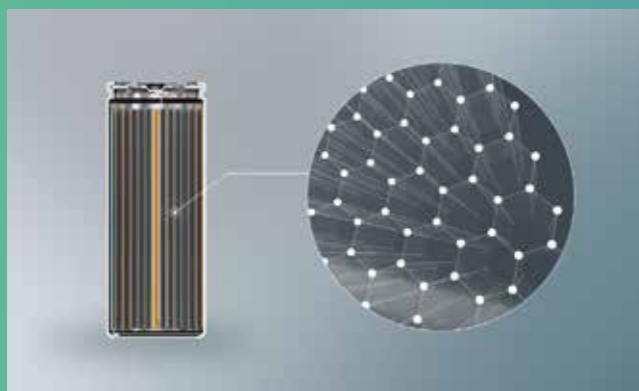
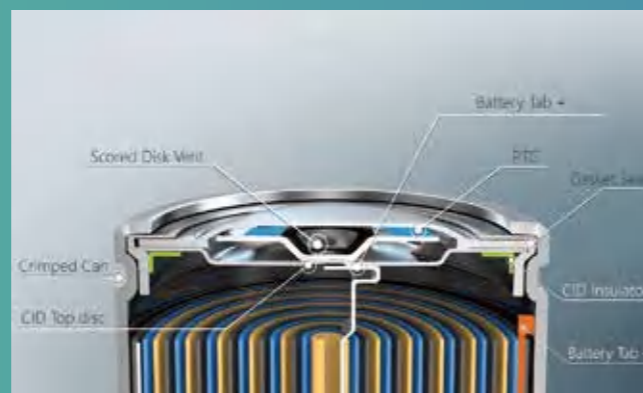

Graphene battery is the latest battery system provided by Haidi Energy with our abundant experience in graphene lithium battery production.

CELL TRACEABILITY

MES, BDM two big data management system to achieve traceability

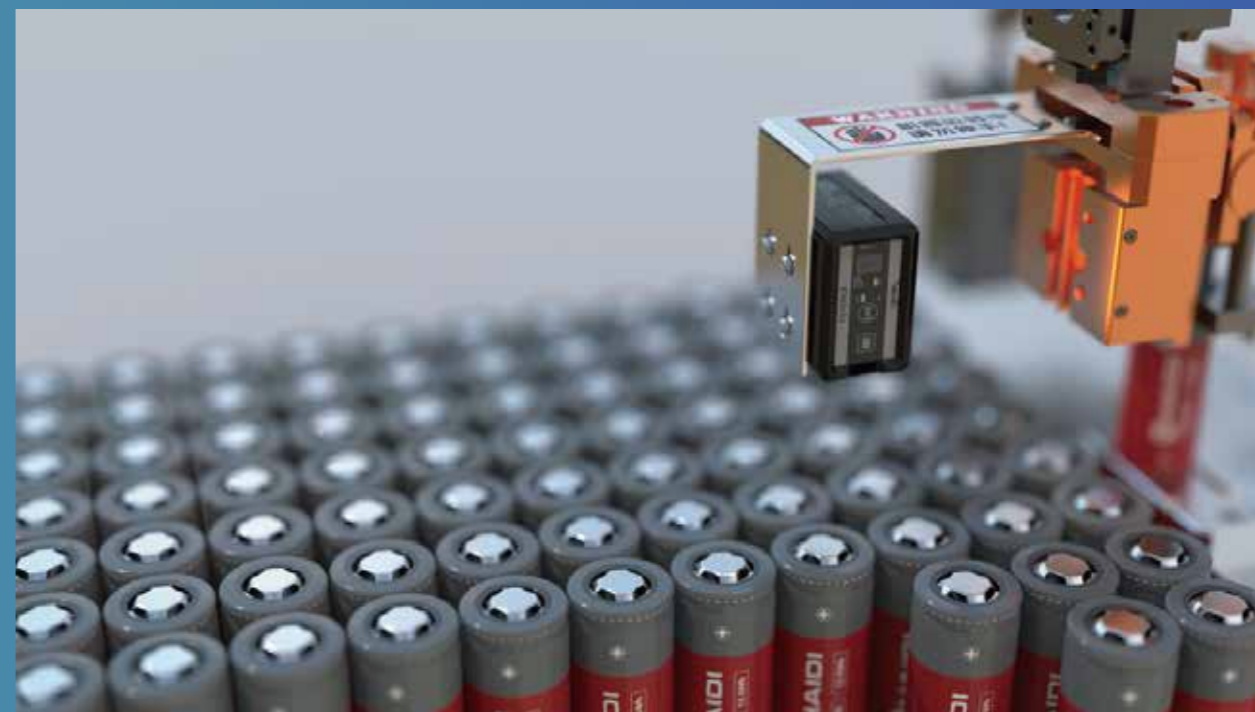

PRODUCT TRACING

Build a big data system that affects product quality from raw materials, production process, equipment state, environment state, etc. Each cell has its genetic information.

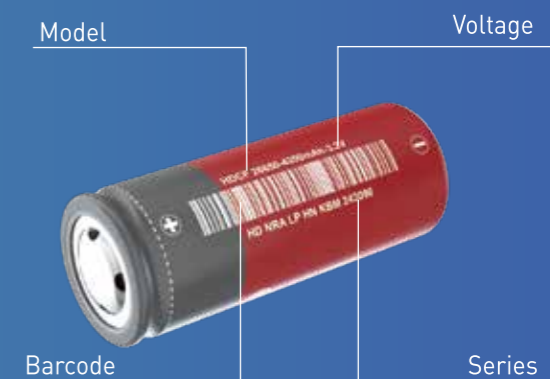

Explain:

1. Each cell has a unique serial number, including model, batch, and serial number.
2. Entering the information into the database, tracing the corresponding production lines, batches, machines, important raw materials, and related quality information.

LIFEP04 Prismatic Cell

A prismatic lithium battery can be encased in either steel or aluminum, which mainly increases the stability of battery cells. Haidi's unique design tends to make our prismatic cells thin and light, and also with the feature of space saving. The rectangular shape of thin prismatic cells offer better layering than cylindrical cells, giving more flexibility for battery design engineers.



FEATURES:

- Qualified for RoHS and CCC with high safety
- Anti-explosion safety valve
- Aluminium shell for better cooling
- Ceramic membrane used to enhance safety
- High density
- High charge/discharge rates
- Expected to operate for more than 4,000 cycles in optimal working conditions

- Continuous Discharge Current: 1C
- Pulse Current: 3C
- Maximum Continuous Charge Current: 2C
- Recommended Charge Current 0.6C/1.2C
- 4,000 cycles in nominal conditions when cycled between 100% (3.65V) to 0% (2.5V) until 80% of original capacity

Part Number	Nominal Voltage	Rated Capacity	Discharge Rate	Dimension(mm)			Weight(kg)
				Length	Width	Height	
HD3.2-50	3.2V	50Ah	1C	148±0.1	27.5±0.1	134±0.1	1.1
HD3.2-100	3.2V	100Ah	1C	160±0.1	50.1±0.1	118.5±0.1	1.9
HD3.2-105	3.2V	105Ah	1C	148.3±0.1	52.4±0.1	119±0.1	1.9
HD3.2-105HP	3.2V	105Ah	2C	174.6±0.1	27±0.1	207±0.1	2.1
HD3.2-206	3.2V	206Ah	1C	173.8±0.1	54.3±0.1	200±0.1	4.1
HD3.2-206HP	3.2V	206Ah	2C	174.6±0.1	54±0.1	207.1±0.1	4.2
HD3.2-280	3.2V	280Ah	1C	174.7±0.1	71.6±0.1	207.1±0.1	5.4

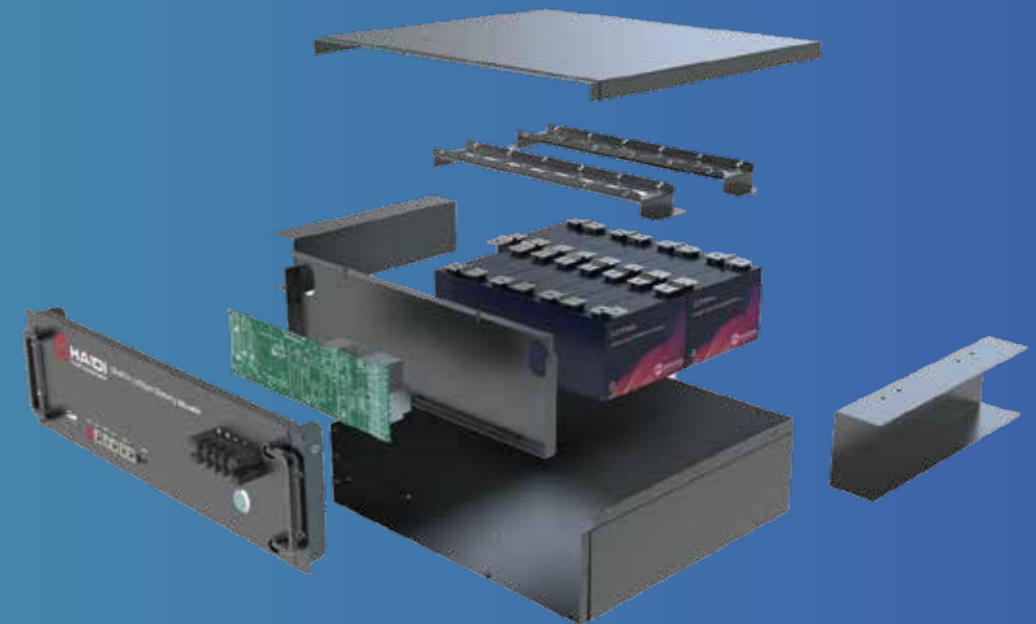

Very long cycle life

Non-hazardous

No. Min Very low Internal resistance

Light weight

Wide temperature range

Maintenance free

Lithium Battery Modules

Based on the company's proprietary lithium iron phosphate coating technology, the modules composed of LFP cylindrical cells deliver an industry-leading combination of energy density, cycle life, and safety.

Haidi's compact and lightweight modules are ideal for portable, mobile, stationary or EV applications where space, weight, and maintenance concerns are important.



LiFePO4 Module

Part Number	Nominal Voltage	Rated Capacity	Dimension(mm)			Total Height	Terminal	Weight(Kg)
			Length	Width	Height			
HDF3.2-50	3.2V	50Ah	181	77	105	120	M8	2.2
HDF3.2-100	3.2V	100Ah	187	78	170	246	M8	3.5
HDF3.2-150	3.2V	150Ah	278	77	168	142	M8	5.7
HDF3.2-200	3.2V	200Ah	186	81	271	278	M8	7.2

NMC Module

Part Number	Nominal Voltage	Rated Capacity	Dimension(mm)			Total Height	Terminal	Weight(Kg)
			Length	Width	Height			
HDN3.7-72	3.7V	72Ah	181	77	105	120	M8	2.3
HDN3.7-144	3.7V	144Ah	187	78	170	246	M8	3.6
HDN3.7-215	3.7V	215Ah	278	77	168	170	M8	5.9
HDN3.7-288	3.7V	288Ah	186	81	271	271	M8	7.3

Lithium Battery Module Datasheet

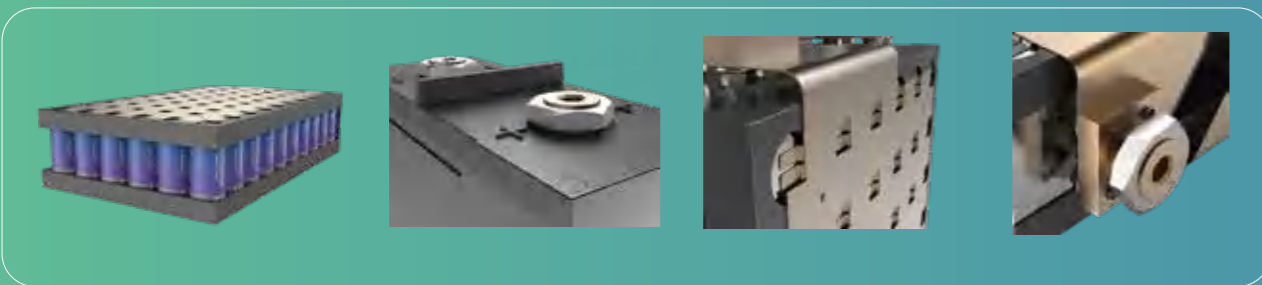

Battery Module Detail

- Industry-leading cycle life
- High charge and discharge capability
- Ultra safety performance
- Wide operating temperature range
- Module design easy for installation
- Flame Retardant Housing

Lithium Battery Modules

This new series of scalable lithium-ion based battery modules built on cylindrical cell technology is a game-changer. Think of these modules as the "building blocks" for your next power management project. These robust lithium battery modules are perfect for use in electric energy storage and mobility systems. Multiple modules can be configured together in series or parallel to increase voltage or capacity as needed (12v, 24v, 48v, etc.). Our flexibility of cell options and chemistries allows our customers on nearly any type of commercial, industrial, and OEM project.

Cycle Life
6000 up to times
(80% DoD, 0.2C, 25°C)

Scalable design means faster go-to-market for customers with custom modules

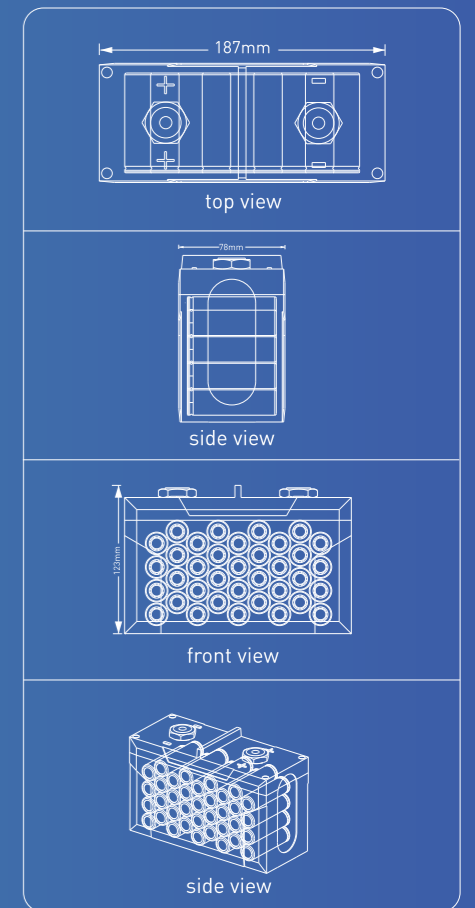
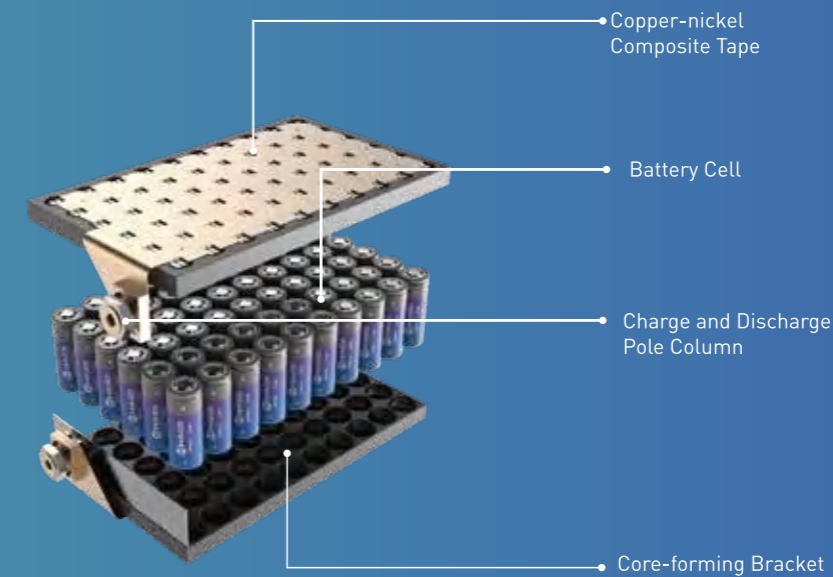

Advantage Features:

- ENVIRONMENTAL
- RECYCLING
- GREEN ENERGY
- THINK GREEN
- GREEN INNOVATION
- ENERGY CONSUMPTION
- PLANT CONSUMPTION
- ENERGY DEVELOPMENT

REPLACE LITHIUM LEAD ACID

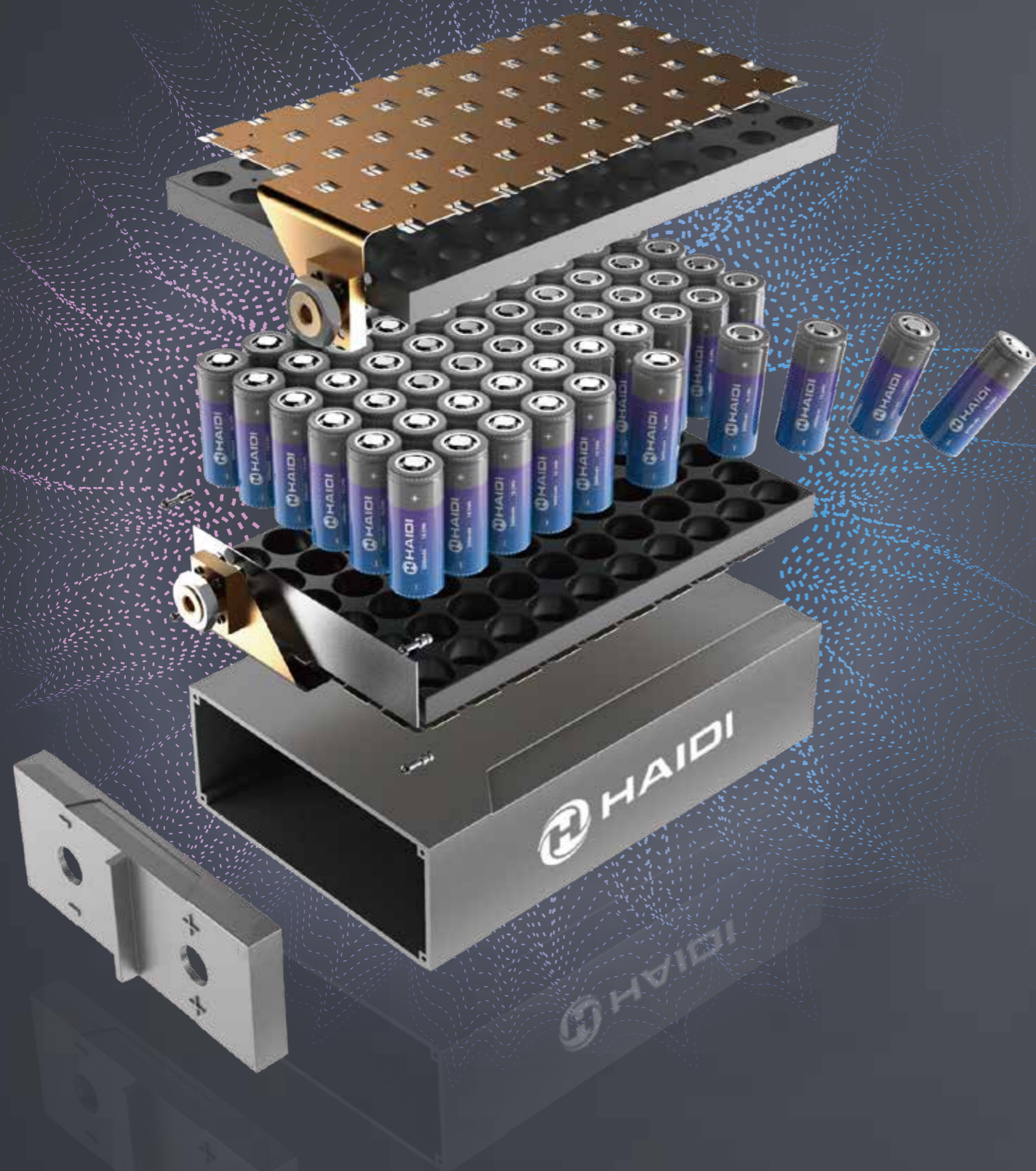

The Haidi Lithium Iron Phosphate Battery is perfect for deep-cycle applications including cabins, solar/wind energy systems, UPS battery backups, telecommunication systems, medical equipment, and more. Unlike gel or lead-acid batteries, the Haidi LFP battery is safer, lighter, and more powerful with a long service and shelf life. Invest in this sealed, maintenance-free battery for your off-grid system today.



Lead Acid Replacement Lithium Batteries

FEATURES:

Lithium Iron Phosphate (LiFePO4): the Safest Lithium Technology.

Integrated Battery Management System(BMS).

Bluetooth/RS485/RS232/SMBus/CANBus (Optional).

SOC LED/LCD Indicator(Optional).



Part No.	HD6-4.5	HD12-4.5	HD12-7.5	HD12-12	HD12-18	HD12-20	HD12-26	HD12-33	HD12-40
Nominal Voltage (V)	6.4	12.8V	12.8V	12.8V	12.8V	12.8V	12.8V	12.8V	12.8V
Rated Capacity (Ah)	4.5	4.5	7.5	12	18	20	26	33	40
Typical Energy (Wh)	28.8	57.6	96	153.6	230.4	256	332.8	422.4	512
Max. Charge Current	4.5A	4.5A	7.5A	12A	18A	20A	26A	33A	40A
Max. Discharge Current	9A	9A	15A	15A	20A	20A	26A	33A	40A
Discharge Cut-off Voltage	5V	10V	10V	10V	10V	10V	10V	10V	10V
Internal Resistance	≤60mΩ	≤30mΩ	≤30mΩ	≤30mΩ	≤30mΩ	≤30mΩ	≤30mΩ	≤30mΩ	≤30mΩ
Charge Method	Use a constant current, constant voltage (CC/CV) charging regime								
Cycle Life	>4200cycles@1C, 80% DOD								
Dimension(mm)	70*47*101	90*70*101	151*65*94	152*99*96	181*77*167	181*77*167	166*175*125	195*130*180	197*165*170
Weight(kg)	0.34	0.75	1.1	1.7	2.6	2.8	4.2	4.8	5.75
Terminal	F1	F1	F1	F2	M5	M5	M5	M6	M6

Part No.	HD24-10	HD24-20	HD24-50s	HD24-50	HD24-75	HD24-100	HD24-125	HD48-20	HD48-50
Nominal Voltage (V)	25.6V	25.6V	25.6V	25.6V	25.6V	25.6V	25.6V	51.2V	51.2V
Rated Capacity (Ah)	10	20	50	50	75	100	125	20	50
Typical Energy (Wh)	256	512	1280	1280	1920	2560	3200	1024	2560
Max. Charge Current	10A	20A	50A	50A	75A	100A	125A	20A	50A
Max. Discharge Current	10A	20A	50A	50A	75A	100A	125A	20A	50A
Discharge Cut-off Voltage	20V	20V	20V	20V	20V	20V	20V	40V	40V
Internal Resistance	≤30mΩ								
Charge Method	Use a constant current, constant voltage (CC/CV) charging regime								
Cycle Life	>4200cycles@1C, 80% DOD								
Dimension(mm)	181*77*165	197*165*170	306*168*210	330*173*212	483*170*238	522*240*224	522*240*224	522*240*224	
Weight(kg)	2.8	5.75	13.6	13.6	16.5	29.6	32.7	10.8	30
Terminal	M5	M6	M8	M8	M8	M8	M8	M8	M8

6V & 12V & 24V Series



Part No.	HD12-45	HD12-50	HD12-55	HD12-60	HD12-65	HD12-70	HD12-75	HD12-80	HD12-85
Nominal Voltage (V)	12.8V	12.8V	12.8V	12.8V	12.8V	12.8V	12.8V	12.8V	12.8V
Rated Capacity (Ah)	45	50	55	60	65	70	75	80	85
Typical Energy (Wh)	576	640	704	768	832	896	960	1024	1088
Max. Charge Current	45A	50A	55A	60A	65A	70A	75A	80A	85A
Max. Discharge Current	45A	50A	55A	60A	65A	70A	75A	80A	85A
Discharge Cut-off Voltage	10V	10V	10V	10V	10V	10V	10V	10V	10V
Internal Resistance	≤30mΩ								
Charge Method	Use a constant current, constant voltage (CC/CV) charging regime								
Cycle Life	>4200cycles@1C, 80% DOD								
Dimension(mm)	197*165*170	275*132*200	228*138*228	260*168*208	260*168*208	260*168*208	260*168*208	260*168*208	260*168*208
Weight(kg)	7.52	8.12	8.21	8.82	9.3	9.8	10.8	11.3	12.2
Terminal	M6	M6	M6	M6	M6	M6	M6	M6	M6

Part No.	HD12-90	HD12-100s	HD12-100	HD12-120	HD12-120s	HD12-150	HD12-200	HD12-250	HD12-300
Nominal Voltage (V)	12.8V	12.8V	12.8V	12.8V	12.8V	12.8V	12.8V	12.8V	12.8V
Rated Capacity (Ah)	90	100	100	120	120	150	200	250	300
Typical Energy (Wh)	1152	1280	1280	1536	1536	1920	2560	3200	3840
Max. Charge Current	90A	100A	100A	120A	120A	150A	200A	200A	200A
Max. Discharge Current	90A	300A	300A	300A	300A	300A	300A	300A	300A
Discharge Cut-off Voltage	10V	10V	10V	10V	10V	10V	10V	10V	10V
Internal Resistance	≤30mΩ								
Charge Method	Use a constant current, constant voltage (CC/CV) charging regime								
Cycle Life	>4200cycles@1C, 80% DOD								
Dimension(mm)	260*168*208	306*168*210	330*173*212	410*177*225	355*175*190	483*170*238	522*240*224	522*240*224	522*240*224
Weight(kg)	13.1	13.6	13.6	15.5	13.1	16.5	29.6	33	40.1
Terminal	M6	M8	M8	M8	M8	M8	M8	M8	M8

Replace SLA Batteries with Li-Ion Technology



Long Shelf Life

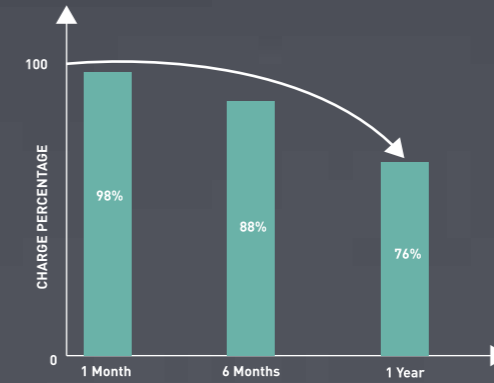

Low Self-Discharge

A low discharge rate means less worry when stored. Battery loses about 2% charge per month! Which is possible due to the nature of Lithium Iron Phosphate batteries and their high energy density. Meaning a fully charged LiFePO4 Battery can potentially hold a charge up to 1 year.

BMS

Our battery management system utilizes only the highest quality components and is manufactured specifically for our LiFePO4 cells to boost performance and maximize lifespan, as opposed to competitors who source boards and parts from various, unreliable suppliers.

Cells

Our cells undergo a strict and selective quality control process that ensures only the best A-grade cells make it into the final battery

The cells are certified with UL1642 as a testament to their safety and performance

Any cell that reaches the final stage of production is confidently given an official rating of up to 7000 cycles.

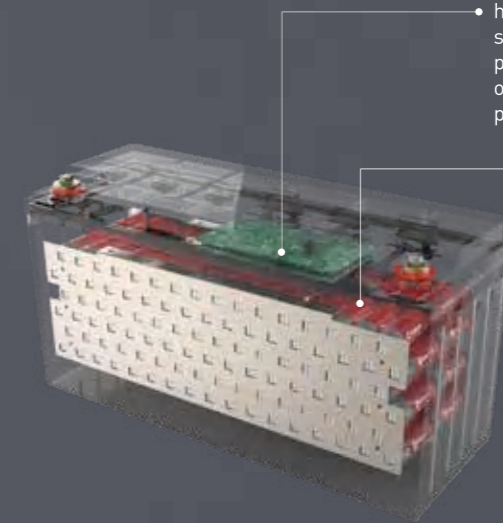

LiFePO4 vs SLA Batteries

LIFE TIME	LiFePO4 BATTERY	10 Yrs.
	SLA BATTERY	4 Yrs.
CYCLES	LiFePO4 BATTERY	>2,500
	SLA BATTERY	~200
COST PER CYCLE	LiFePO4 BATTERY	\$
	SLA BATTERY	\$\$\$
WEIGHT	LiFePO4 BATTERY	1/3
	SLA BATTERY	3x the Weight



Control all

HAIDI SMART BATTERY

With this remote control App

User friendly interface

A fully function remote control



KEY FEATURES

Designed for Safety

Extremely safe lithium iron phosphate cells, fully sealed and sturdy waterproof housing helps keep the battery from leaking or corrosion.

Extended Lifespan

With more than 2000 cycles the service life is more than double that of traditional lead acid batteries.

Battery Management System (BMS)

The built-in battery protection system optimizes the battery performance by automatically balancing the cells and providing multiple protections against over-charging, over-discharging, over-current, short-circuit and over-temperature.

Wide range of applications

Widely used in RV, Marine and solar applications.

Low self-discharge

The battery self-discharges below 2% per month, providing optimal longevity and shelf life.

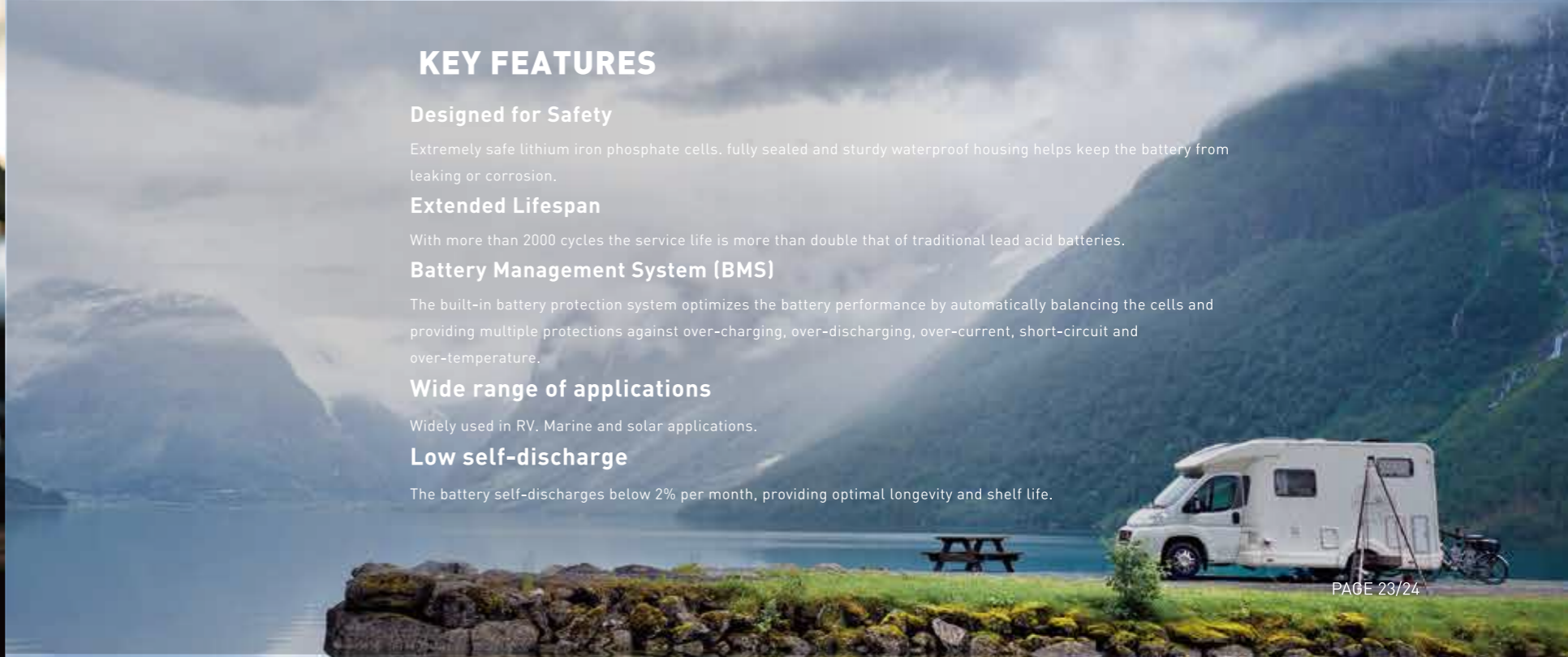

Automotive Starting Battery

LITHIUM IRON PHOSPHATE TECHNOLOGY

Patented Graphene Coating Technology

The battery is at the heart of the car. It powers everything – from the ignition to continuously operating vehicle electric systems and onboard entertainment systems. The battery ensures constant power for all other functionalities during the start-stop process.

Power up your machine with patented graphene coating technology lithium battery and ride smoothly, no matter how far away your destination may be. This long-lasting battery recharges quickly to get you going faster and keep you going longer. Strength and efficiency come in the form of high discharging battery pack design, providing the best and most proficient power-per-pound available.

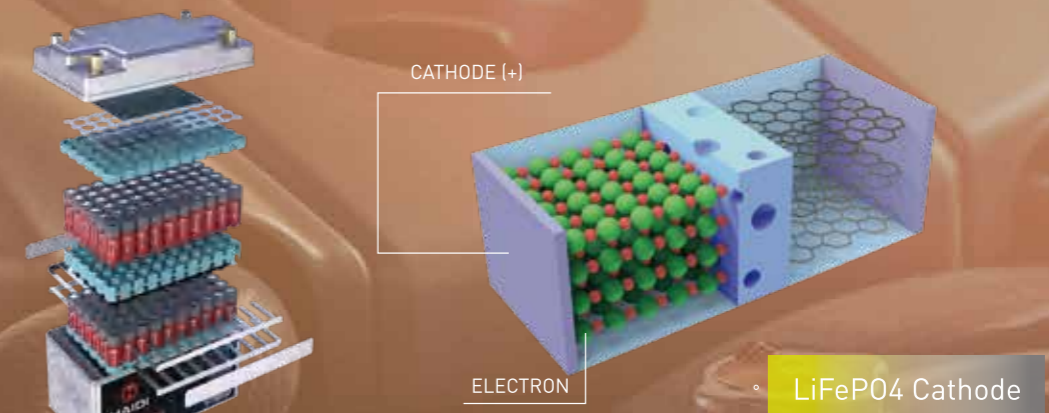

Haidi lithium iron phosphate batteries are specially developed to handle high discharge currents. You can start heavy engines easily or use several electrical devices at the same time on your boat or RV.

Lightweight, high-performance, safe and reliable lithium power battery, especially developed for automotive.

Lithium iron phosphate batteries offer lots of benefits compared to lead-acid batteries and other lithium batteries. Longer life span, no maintenance, extremely safe, lightweight, improved discharge and charge efficiency, just to name a few. LiFePO4 batteries are not the cheapest in the market, but due to a long life span and zero maintenance, it's the best investment you can make over time.

Part Number	HSP-1230	HSP-1240	HSP-1250	HSP-1260	HSP-1270	HSP-1280	HSP-1290	HSP-12100	HSP-12120
Norminal Voltage	12.8V								
Input Voltage	≤14.6V								
Rated capacity	30Ah	40Ah	50Ah	60Ah	70Ah	80Ah	90Ah	100Ah	120Ah
Discharge current	100A	150A	200A						
CCA	600A	800A	1000A			1500A	1200A	1500A	
Cycle life	Start≥100,000 times								
Operating Temp	-30°C~80°C								
Battery weight	5.2Kg	6.5Kg	7.6Kg	8.5Kg	9.2Kg	10Kg	11Kg	13Kg	15Kg
Battery dimensions	240 x 175 x 190 mm			278 x 175 x 190 mm			322 x 175 x 190 mm		



Power Tool Batteries

Haidi durable metal frame battery construction with shock-responsive separators preventing pack failure from excessive vibrations or drops. Individual cell monitoring ensures optimal charge and discharge for maximum life. Water protection routes water away from the electronics and out of the battery pack. Operating in extreme temperatures down to -20°C without compromising on runtime and battery life.

Li-THIUM

- ★ Less volume and weight - 1/3 of normal lead-acid battery
- ★ No pollution - does not contain any acid and heavy metals such as lead, cadmium, hydrargyrum (mercury)
- ★ No spill - no acid inside, no leak problems
- ★ Super cranking power - cranking current greater than 40C (lead-acid battery 10C)
- ★ Quick recharge with big current - rechargeable with 1C current and 90% recharged within 1 hour
- ★ Excellent cycle life - more than 2000 cycles (lead-acid battery only 150-300 cycles)
- ★ Longer shelf life - more than one year (lead-acid battery 6 months)
- ★ Super performance - stable performs at high temperatures of 60-80°C
- ★ Save energy - stable discharge voltage and lower internal resistance Ultra safe - nonexplosive and noncombustible



HSP12.8-50(30/40/50)

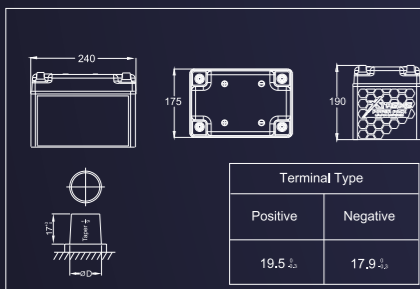

HSP12.8-80(60/70/80)

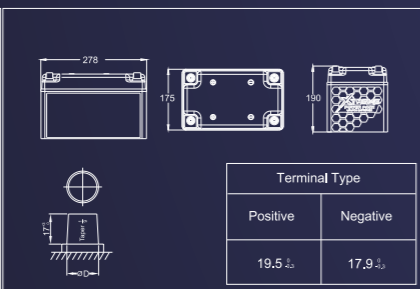

HSP12.8-120(90/100/120)

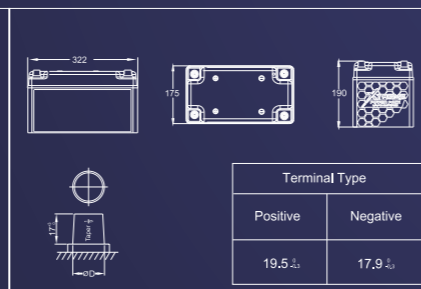

Power Tool Batteries are commonly used by:

- Builders
- Engineers
- Electricians
- Plumbers
- DIY ers



To serve the power tool applications, Li-ion batteries have been modified to operate at high discharge rates. So, while the standard Li-ion batteries specify their capacity at a 1C (or even lower) discharge rate, high-power Li-ion batteries typically specify performance at a 10C or higher rate.

Haidi continues to develop cells with a high discharge rate/higher power capability. A recent example is Haidi's HDPF18650-3.2V-1100mAh, a cell that specifies a typical capacity of 1100 mAh. The cell achieves this minimum capacity at a 30C (33A) discharge rate.

- Extended runtime and optimised power to complete applications quickly
- Lightweight design provides the user with upgraded 4Ah power without increasing the size or weight over the 18v 3Ah battery pack
- No memory effect and virtually no self-discharge, ensuring maximum productivity and less downtime
- LED 'State of Charge' Indicator helps manage charging



Electrical Parameters

Battery type	Rechargeable Lithium battery
Nominal voltage	10.8V
Rated capacity	2000mAh
Energy	21.6Wh
Storage temperature	-5°C - 35°C
Self discharge	2% per Month
Inner resistance	≤ 20mΩ
Total weight(g)	189.5 ± 10g
Size (L*W*H)	46.52 * 50.34 * 83.38 mm



Power Tool Batteries



Electrical Parameters

Battery Type	Rechargeable Lithium battery	Rechargeable Lithium battery	Rechargeable Lithium battery
Nominal voltage	18V	18V	10.8V
Rated capacity	5000mAh	6000mAh	2000mAh
Energy	90Wh	108Wh	21.6Wh
Storage temperature	-5°C - 35°C	-5°C - 35°C	-5°C - 35°C
Self discharge	2% per Month	2% per Month	2% per Month
Inner resistance	≤ 20mΩ	≤ 18mΩ	≤ 20mΩ
Total weight(g)	610 ± 10g	610 ± 10g	189.5 ± 10g
Size (L*W*H)	112 * 72 * 76 mm	112 * 72 * 76 mm	46.52 * 50.34 * 83.38 mm

THE POWER BEHIND EMERGENCY LIGHTING



We believe that, in the short term, Nickel Metal Hydride (NiMH) batteries will replace Nickel Cadmium (NiCd) batteries but LiFePO₄ will gain more popularity in long term. As for LiFePO₄, owing to its environmental protection feature, the large capacity and low prices, LiFePO₄ will be a new direction in the near future depending on the issuance and improvement of the regulations in the future.



excellent charging performance at high temperatures.



extremely low self-discharge

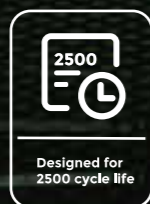

Designed for 2500 cycle life

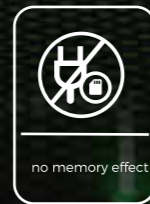

no memory effect



fast to charge

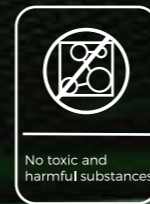

No toxic and harmful substances.

Advantages of lithium Iron phosphate batteries

EXIT

Emergency Lighting

Model No	Battery Cell	Configuration	Dimension(mm)	Weight(g)
HDEL3.2V1.5Ah	HDCF18650-1500-3.2V	1S1P	72 Φ 18.5	42
HDEL3.2V3.0Ah	HDCF18650-1500-3.2V	1S2P	72*37*20	44
HDEL6.4V1.5Ah	HDCF18650-1500-3.2V	2S1P	72*37*20	44
HDEL6.4V3.0Ah	HDCF18650-1500-3.2V	2S2P	136*37*20	165
HDEL9.6V1.5Ah	HDCF18650-1500-3.2V	3S1P	72*40*39	123
HDEL9.6V3.0Ah	HDCF26650-3000-3.2V	3S1P	72*56*54	259
HDEL9.6V6.0Ah	HDCF26650-3000-3.2V	3S2P	96*72*50	425
HDEL12.8V1.5Ah	HDCF18650-1500-3.2V	4S1P	71*44*44	165
HDEL12.8V3.0Ah	HDCF26650-3000-3.2V	4S1P	123*72*20	340
HDEL12.8V6.0Ah	HDCF26650-3000-3.2V	4S2P	123*72*50	680

Haidi has extended its product portfolio and have developed a special lithium batteries of unique chemical compositions and electrolyte, with regard to performance over lifetime and possible safety issues in terms of high temperature, flames and mechanical damage. Besides the benefits of a very high energy density, and a long lifetime up to twice that of the NiCd or NiMH batteries, Haidi 18650 LiFePO₄ EM range cells stand out due to its excellent performance and safety in all of the performed emergency lighting tests.

Maximum Charge/Discharge Cycles Versus Battery Type

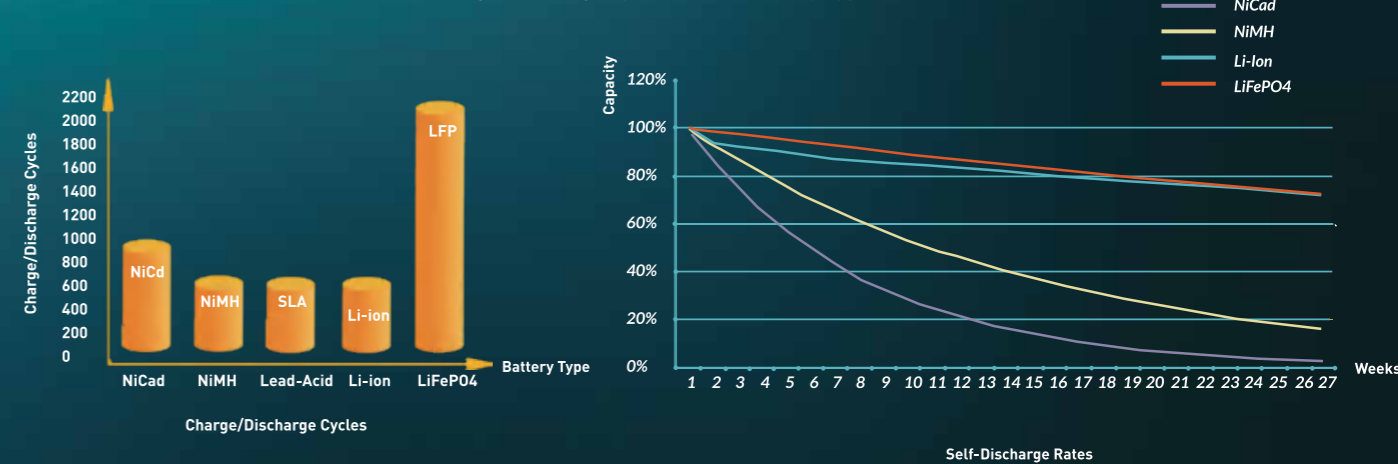

Emergency Lighting Batteries



The outlook of emergency battery pack in coming future

There are now more and more concerns around the toxic and harmful substances found in Ni-CD and SLA batteries. These toxic substances are harmful to humans and the environment if not disposed and recycled properly. In view of environment and health, Lithium Iron Phosphate contains no toxic heavy metals and no carcinogens. This provides a significant reason to consider lithium-ion over Ni-CD batteries.



HDEL12.8-1.5
12.8V1.5Ah,(19.2Wh)



HDEL6.4-1.5
6.4V1.5Ah,(9.6Wh)



HDEL6.4-3.0
6.4V3.0Ah,(19.2Wh)



HDEL9.6-2.0
9.6V2.0Ah,(19.2Wh)



HDEL9.6-1.5
9.6V1.5Ah,(14.4Wh)

Solar Street Lamp Batteries



Tough Environment Acclimation Ability

Haidi Lithium batteries are designed to operate in extreme weather conditions with a wide temperature range of $-40\sim 65^{\circ}\text{C}$, and dust and water proof. Excellent environment resistance characteristics keep solar street lights lighting in any rough conditions for your needs.

Long Cycle Life

Rechargeable lithium-ion batteries in solar street lights run for $8 \times$ more than SLA batteries.



Chemistry:
LiFePO₄/NMC



Nominal Capacity:
10Ah-100Ah



Integrated Protection
Circuit Module



Operating Temperature:
 $-40^{\circ}\text{C}\sim 65^{\circ}\text{C}$



Nominal Voltage:
11.1V,12.8V,24V,25.6V.



LITHIUM BATTERY ENERGY STORAGE SYSTEM

Powerful, Pratical, Proven

ENERGY STORAGE

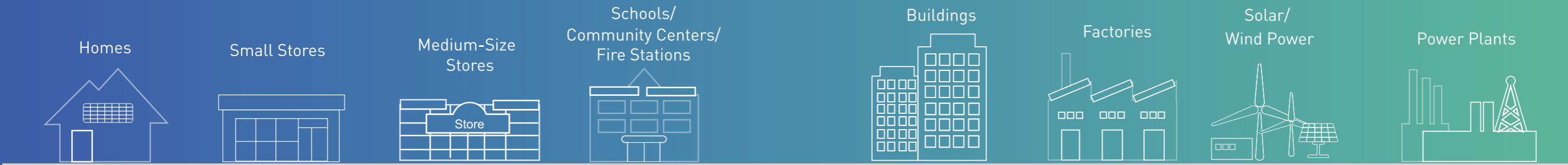

Technology From The Front Line

Haidi Powerbox provides the perfect solution to optimize the use of self-generated solar energy. Use your own solar energy directly, store for later use or earn money by feeding the energy back to the grid at higher tariffs.

Haidi Powerbox is a high tech Energy Storage System (ESS) that uses NMC (Nickel Manganese Cobalt) and LiFePO4 (Lithium Iron Phosphate) which has a higher safety rating and longer life . Both products are used globally and are more than sufficient for European and Central Asia conditions. NMC and LiFePO4 cells are the core of haidi Powerbox and are testament to solar power cutting edge technology and commitment to supplying households with nothing but the most reliable, safe and economical batteries available. All our products adhere to all European (CE) and German (TÜV) standards.

Every household and business has its own particular energy needs. At haidi we are committed to not only bringing technology from the front line but also giving each home the flexibility to be truly modular. We offer our typical 7.5KWh and 10KWh Powerbox ESS but we can link them together to expand capacity as the solution may require..

POWERBOX

Powerbox Specification

Physical			
Model No	F7-7.3KWh	F10-10kWh	N10-10kWh
Battery Pack	51.2V144Ah	51.2V200Ah	51.8V205Ah
Battery Type	LiFePO4 Chemistry	LiFePO4 Chemistry	NCM Chemistry
Aprox Weight	105kgs	136kgs	105kgs
Dimension	640*172*1150mm	643*185*1053mm	640*172*1150mm
Protection Level		IP20	

Technical Parameter

Nominal Voltage	51.2V	51.2V	51.8V
Rated Capacity	144Ah	200Ah	205Ah
Discharge Current	100A	200A	100A
Charge Current	< 100A	< 100A	< 100A
Discharge Cut-off Volt.	37.5V	37.5V	37.5V
Charge Mode	CC/CV	CC/CV	CC/CV
Charge Voltage	58.4V	58.4V	58.8V
Working Temperature	-20°C~+60°C	-20°C~+60°C	-20°C~+60°C
Humidity	5% ≤ RH ≤ 95%	5% ≤ RH ≤ 95%	5% ≤ RH ≤ 95%
Communication	CAN/RS485/RS232	CAN/RS485/RS232	CAN/RS485/RS232
Max. Parallel	32 Modules	32 Modules	32 Modules
Certification	UL1973, TUV CB/IEC62619	UL1973, TUV CB/IEC62619	UL1973, TUV CB/IEC62619

Electrical Parameter

Cycle Life	≥5000 Cycles	≥5000 Cycles	≥2000 Cycles
Life Span	20 Years	20 Years	15 Years
Warranty	Product Warranty: 5 Years Performance Warranty: 5 Years	Product Warranty: 5 Years Performance Warranty: 5 Years	Product Warranty: 3 Years Performance Warranty: 5 Years
Compatible Inverter	Victron, SMA, Voltronic, Studer, Huawei, Sermatec, Sinexcel SolaX Power, Goodwe, Growatt, Sofar		

POWERBOX

Technology From The Front Line

Haidi delivers complete solar and backup power kits for homes, businesses, boats and RVs, remote industrial, and other applications- both on-grid and off-grid. Our systems contain everything you need to go solar: PV panels, solar inverter and optional back-up Lithium battery pack.

Lower your power bill and protect from power outages

Traditional grid-tied solar systems only operate when utility power is available. Without energy storage, a grid-tied PV solar system shuts down during a power outage. The addition of haidi Powerbox Lithium energy system and a backup inverter can provide seamless, uninterrupted power for your household during an outage while still offsetting your power bill.



POWERBOX

Stay energized even when the grid is down

When the grid is available, power produced by your solar system is used by the home and excess energy is sent into the utility grid. In the event of a power outage the backup inverter will automatically turn on to pump critical appliances such as the fridge/freezer, AC, lights, well pump, computer, phone and more. The combination of solar energy and battery storage works seamlessly to provide power to essential appliances during an outage, working similar to an off-grid system.

HAIDI SOLAR SYSTEM FEATURES & BENEFITS

Set for easy installation-perfect for the contractor or handy homeowner.

Systems scalability accordingly specific needs.

Long-term warranty

Compact and robust design

Outstanding performance and reliability

Optimized total cost of ownership

Advanced Battery Management System for safe and efficient operation

Ensured compatibility of all system components

State-of-the-art technology and design

Simplified maintenance and control

High temperature performance



Long cycle life



Module design



Easy for installation



Ultra safety



No pollution



Support system parallel connection



High energy transfer efficiency



High charge & discharge rate



High temperature performance



App control

Energy Storage Systems



Haidi energy storage battery systems for home and small business running over hundred kW are designed to level out peaks in electricity use (peak shaving), shift loads and provide emergency backup and frequency regulation to ensure grid stability and power quality. Energy storage battery systems are often combined with renewable energy sources – including wind and solar power - to smooth-out system varying and intermittent outputs. They usually contain bi-directional DC-AC inverters for grid interfacing and bi-directional DC-DC converters that independently control energy flows to and from each battery rack. This ensures they are kept in their optimal operating state and helps minimize battery imbalance for improved system efficiency, capacity, lifetime and maintenance.

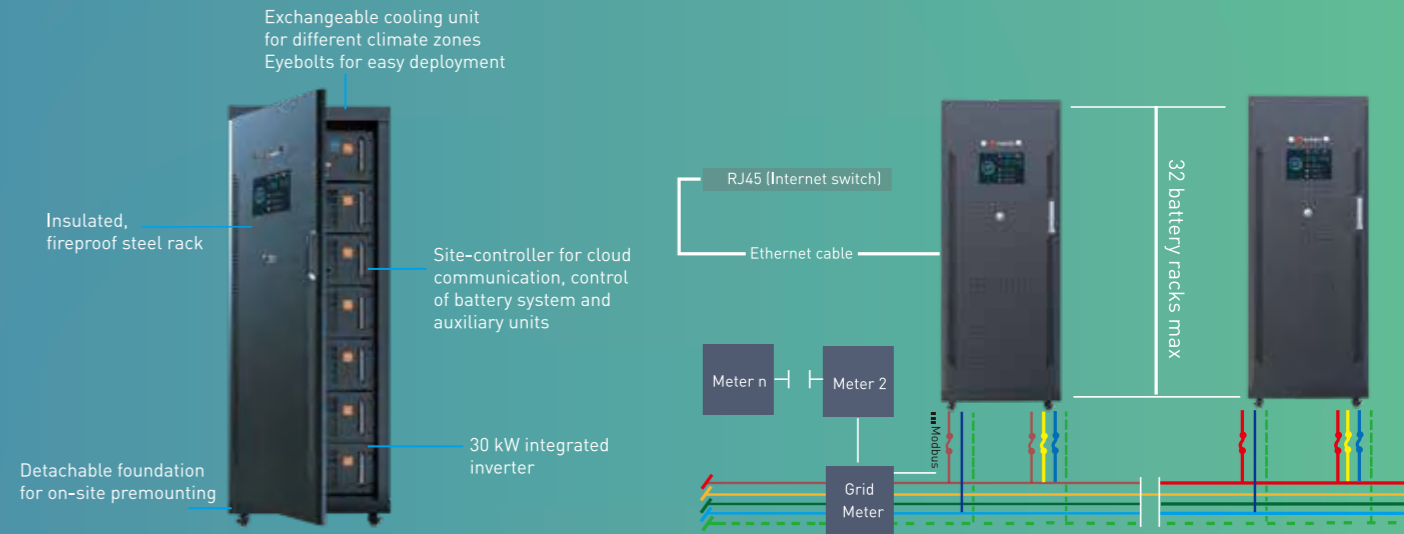

The Haidi Home & Small Business product portfolio has been specially developed for the professional and demanding use of battery storage systems. High-quality battery cells from the industrial sector ensure higher power output and lower capacity losses throughout their operational life than is the case for systems with commercially available consumer cells.

The scalable AC-coupled Haidi products are available with various brands of inverters, in the case of higher power outputs, with directly integrated power electronics.

Haidi products allow your applications to grow with your needs. Our energy management with PV systems, complex hybrid power plants up to central connection allow you to extend cloud services via our icloud platform.

Specifications

Nominal voltage	51.2V/25.6V/Customized
Nominal Capacity	1000AH
Rated Energy	50KWH
Battery Module	25.6V100Ah/48V50Ah/Customized
Module Size	482*650*135 mm
Operating Temperature	0°C-45°C
Maximum Charging Voltage	58.4V ± 0.4V
Rated Charging Voltage	56.0V ± 0.4V
Maximum Charging Current	180A
Rated Charging Current	150A
Operating Temperature	-20°C-65°C
Output Voltage Range	40-58.4V
Peak Discharge Current	360A
Continuous Discharge Current	300A
Discharge Cut-off Voltage	40V
Protocols	RS485, CAN

Typical areas of use efficient energy management

- Large single-family houses and villas
- Guest houses and hotels
- Public buildings, kindergartens, schools, etc.
- Workshops and commercial businesses
- Farms and isolated properties
- Self-contained system such as stand-alone solutions or mountain lodges, etc.

Advantages of professional battery storage systems secure investment for the future

- Industrial battery cells instead of "consumer cells from a notebook"
- Consistently high level of current carrying capacity and performance
- Low capacity losses
- Systems suitable for harsh environments
- Certified individual testing by accredited laboratories instead of simple assessment

Energy Storage Systems For Home & Small Business

Grid		General Parameters	
Voltage range	AC400V ± 15% , 50/60Hz	Dimension (w/d/h)	1275*1000*2200 mm
THD	<3%	Weight	1700kg
Power factor	-0.9 ~ 0.9 [adjustable]	Working temperature	0 °C ~ +55 °C
Rated charge power	50kW	Wiring method	Bottom in and out
Rated discharge power	50kW	Relative Humidity	0~95%
		Work altitude	3000m [100% ACoutput]%
		Cooling	Aircon
Storage		Protection class	
Battery type	Lithium battery	Protection class	IP65
Max chargeable capacity	110kWh	Environment pollution class	Class 1,2,3
Max dis-chargeable capacity	100kWh	Topology structure	
Life cycle	5000	Topology structure	Transformer optional
System efficiency [%]	>88%	Communication	TCP/IP
Efficiency		Compliance	
Max efficiency	>88%		CQC;UL1741;UL9540;CS22.2;
Max charging efficiency	>94%	Connection standard	IEC62477;IEC61000;G59;
Max discharging efficiency	>94%		VDE4105;MEA;AS4777;ERAC
		Safety	IEC62619;IEC62133;IEC62109-1&-2;IEC624777-1
		Transportation compliance	UN38.3

Overview

Battery ,module consists of 36 units of 50Ah LFP cell via 3P12S assembly cell voltage and temperature, cell balances are collected through BSC control system, to secure whole modules are working effectively and smoothly.



Data Sheet

Module capacity	38.4V 150Ah
Assembly method	3P12S
Rated voltage	38.4
Rated capacity	5760Wh
Rated continuous current	75A (0.5C)
Battery module voltage range	30V-43.8V
Work ambient temperature	Charge: 0°C -45°C Discharge: -20°C -55°C
Module weight	80kg
Module dimension (w * d * h)	505*625*190mm
Cooling	Negative

How Energy Storage Works

The curve created by the up and down movement of your monthly energy bills is called the load profile. Businesses with a lot of fluctuation have a "spiky" load associated with drastic shifts throughout the day in how much energy they are consuming. Storage helps reduce that spike.

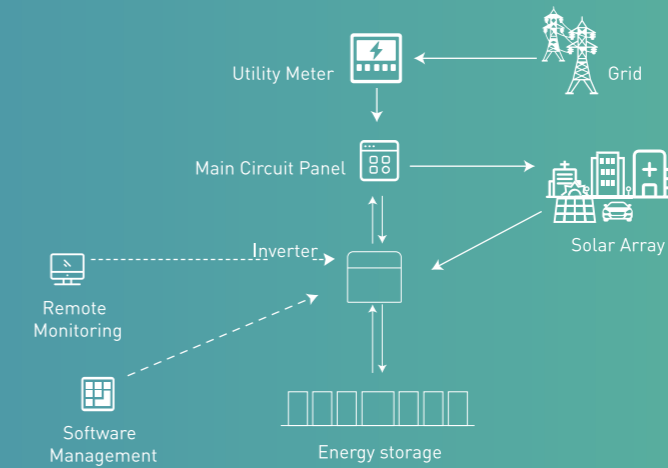

How Energy Storage Works Diagram

SOLAR CHARGES YOUR BATTERIES

During daylight, your solar system uses batteries to store excess energy it generates.

SOFTWARE MONITORS POWER CONSUMPTION

Intelligent software coordinates between solar and storage, optimizing how and when energy is utilized.

BATTERIES RELEASE ENERGY

Stored energy can be released:

- When rates are high
- To keep supply at a consistent level and avoid peak demand charges
- To stay below a certain energy use threshold and avoid moving into a higher rate tariff



HD-ESS 100kWh Front view



HD-ESS 100kWh Energy Storage System Rear view

MEGAWATT ENERGY STORAGE SYSTEM

Haidi's megawatt scale containerized energy storage systems for grids and renewable energy sources provide invaluable flexibility. The containerized energy storage system smooths the intermittent generation and ramp rates inherent in renewable power sources, making it ideal for medium to large-scale, on-grid solar and wind power schemes. Haidi energy storage system is also used in medium and low voltage grids to provide grid support functions such as peak management or voltage support.



Features

Peak load shifting, remote dispatching, demand control, mini grid management

Safety

1. Battery centered design;
2. Three-dimensional protection;
3. Haidi Lithium technology

Stability

1. SoC precision <math>< 2\%</math>;
2. Multiple network structure;
3. Life long period fault and data recording;

High efficiency

1. Battery usable capacity increased by 5%;
2. System efficiency optimization > 1%;
3. Standby consumption decreased over 2.5%;
4. On-site test and commission reduced by 70%;

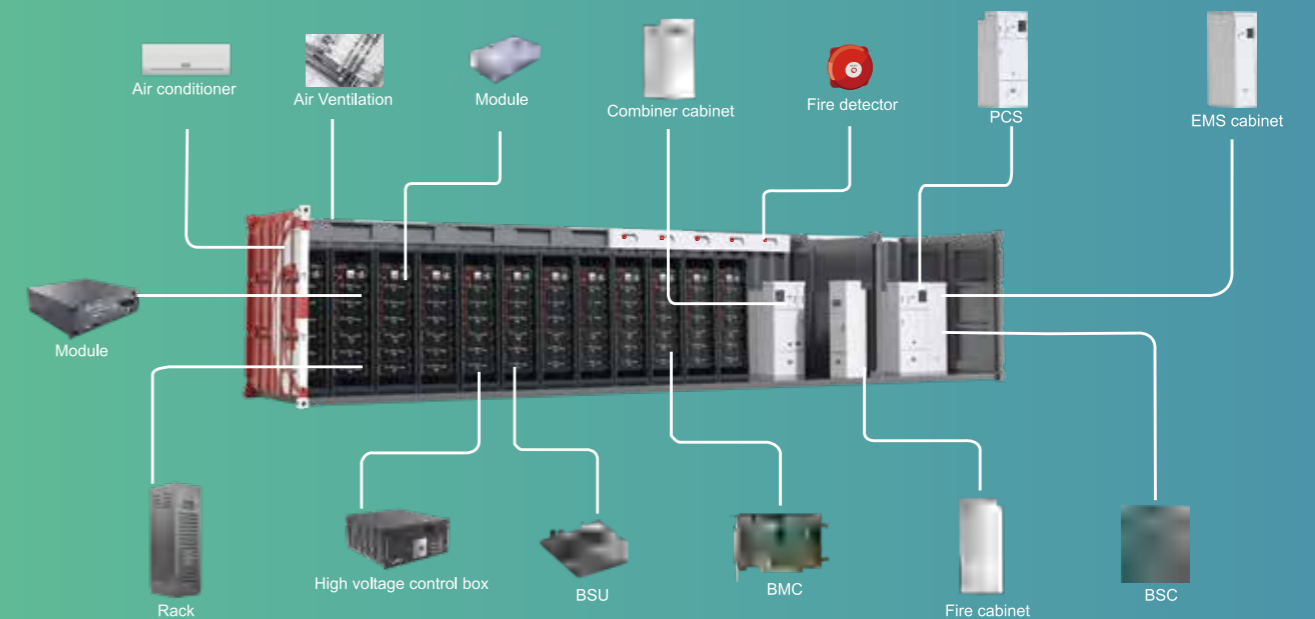

ENERGY STORAGE SYSTEM MODULE DESIGN

- ★ Easy capacity expansion
- ★ Quick and easy installation
- ★ Adaptation of the energy storage to an increased capacity demand

Part Number				
Battery Type	LiFeP04			
Model No	ESS-4850	ESS-4860	ESS-48100	ESS-48150
Battery Pack	48V50AH	48V60AH	48V100AH	48V150AH
Approx Weight	22kgs	26kgs	42kgs	62kgs
Dimensions	480*400*133mm	480*460*133mm	480*460*133mm	480*460*133mm
Water Dust Resistance	IP20			
Energy Capacity	2.4KWh	2.8KWh	4.8KWh	7.2KWh
Usable Capacity	2.4KWh	2.8KWh	4.8KWh	7.2KWh
Cycle Life	≥4000 cycles @100% DOD, ≥6000 cycles @80% DOD, ≥10000 cycles @50% DOD			
Internal Resistance	≤50 mΩ			
Designed Lifespan	≥20 Years, 25 C			
Nominal Voltage	48V			
Rated Capacity	50Ah	60Ah	100Ah	150Ah
Discharge Current	50Ah	60Ah	50Ah	50Ah
Charge Current	≤25A	≤30A	≤50A	≤75A
Discharge Cut-off Volt	37.5V (Can be set)			
Charge Voltage	54V (Can be set)			
Charge Mode	CC/CV			
Working Temperature	-40°C~+ 65°C			
Humidity	5% ≤ RH ≤ 95%			
Communication	RS232 / RS485 / CAN / Ethernet			
Certification	UL1642, TUV, IEC62133 & UN38.3			



PERFORMANCE		
Nominal capacity	770kWh	2000kWh
Rated ratio(C)	0.5C	0.5C
AC output voltage	400Vac	400Vac
AC output frequency	50/60Hz	50/60Hz
Rated power	500kW	500kW
Work mode	On grid & off grid	On grid & off grid
Cycles	≥ 5000 times	≥ 5000 times
Ambient temperature	-40°C~+50°C	-40°C~+50°C
Battery work temperature	15°C~+35°C	15°C~+35°C
Altitude	<3000m	<3000m
Container	20 feet	40 feet
Fire protection grade	IP65	IP65

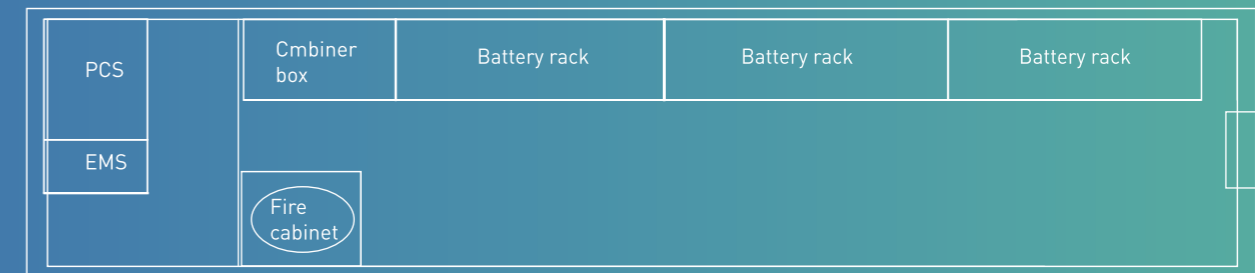

500KW/770KWh Container ESS Layout

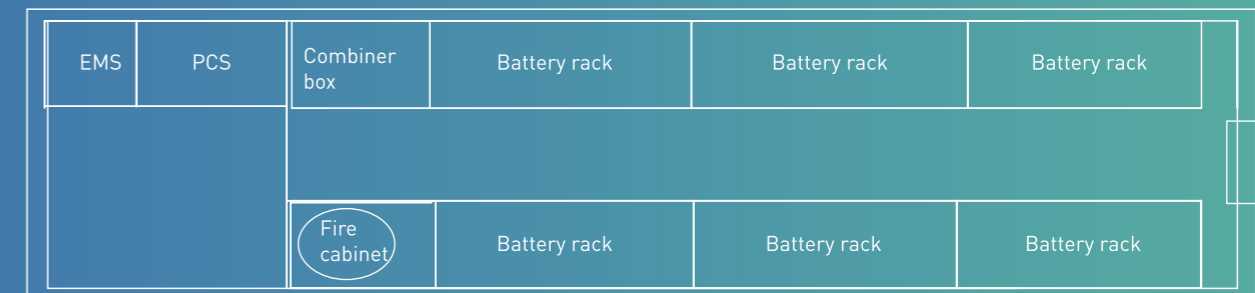

1000KW/1800KWh Container ESS Layout

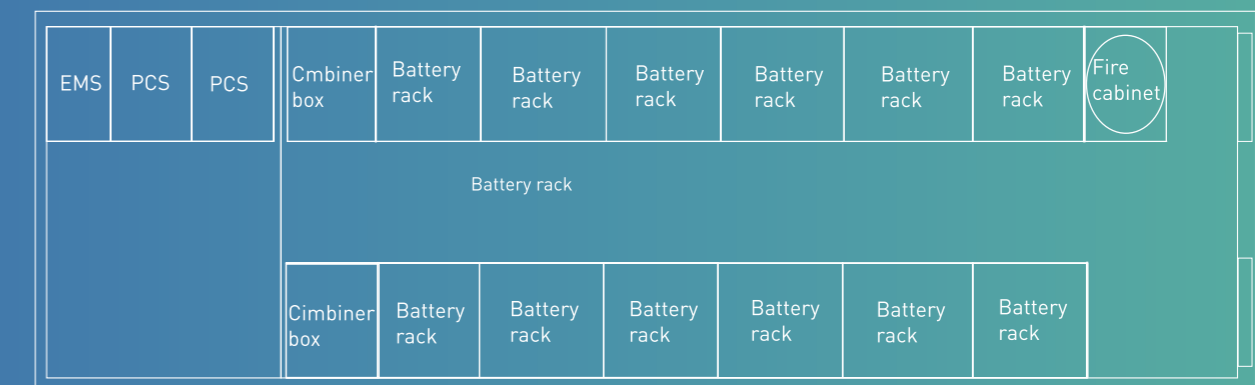

500KW/2000KWh Container ESS Layout

Electric Bike Battery

Haidi Ebike Batteries are an efficient, long-life energy source. Thanks to their enormous mileage, long service life and intelligent battery management system, Haidi lithium-ion batteries are among the most modern on the market.

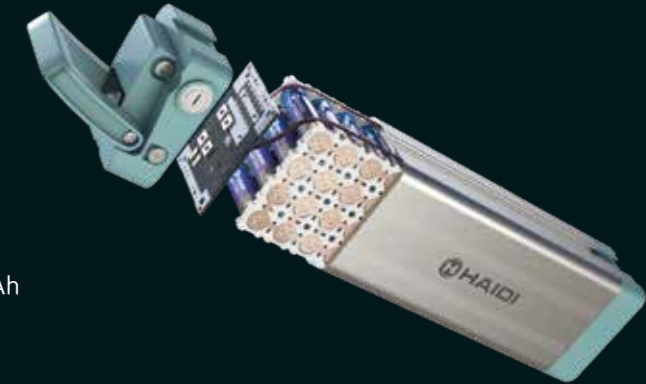

Customized:

Capacity: 10Ah, 11Ah, 13Ah, 14Ah, 15Ah, 17.5Ah, 20Ah, 23Ah, 30Ah

Voltage: 24V, 36V, 48V, 51.2V

Combination: 7S6P/10S8P/13S8P/16S8P/13S10P

Model No	Battery Cell	Voltage	Typical Energy	Combinations	Dimension (customized)	Weight
HDEB24V10Ah	10Ah	24V	240Wh	7S4P	137*90*70mm	1.5kg
HDEB24V15Ah	15Ah	24V	360Wh	7S6P	230*75*70mm	2.2kg
HDEB24V20Ah	20Ah	24V	480Wh	2S1P	395*148*80mm	4.0kg
HDEB36V10Ah	10Ah	36V	360Wh	10S5P	361*90*92mm	3.2kg
HDEB36V13Ah	13Ah	36V	468Wh	10S5P	367*90*111mm	4.0kg
HDEB36V15Ah	15Ah	36V	540Wh	10S5P	367*90*111mm	4.0kg
HDEB36V20Ah	20Ah	36V	720Wh	10S8P	95.19 * 72.78 * 285mm	4.5kg
HDEB48V10Ah	10Ah	48V	480Wh	13S4P	367*90*111mm	4.0kg
HDEB48V13Ah	13Ah	48V	624Wh	13S5P	367*90*111mm	4.0kg
HDEB48V15Ah	15Ah	48V	720Wh	13S6P	107.31*75.38*285mm	5.0kg
HDEB48V20Ah	20Ah	48V	960Wh	13S8P	360*150*110mm	6.0kg
HDEB48V30Ah	30Ah	48V	1440Wh	13S10P	360*150*110mm	8.0kg

Note: We also support customized battery design and production.

Outstanding battery efficiency

Simple to store and quick to charge

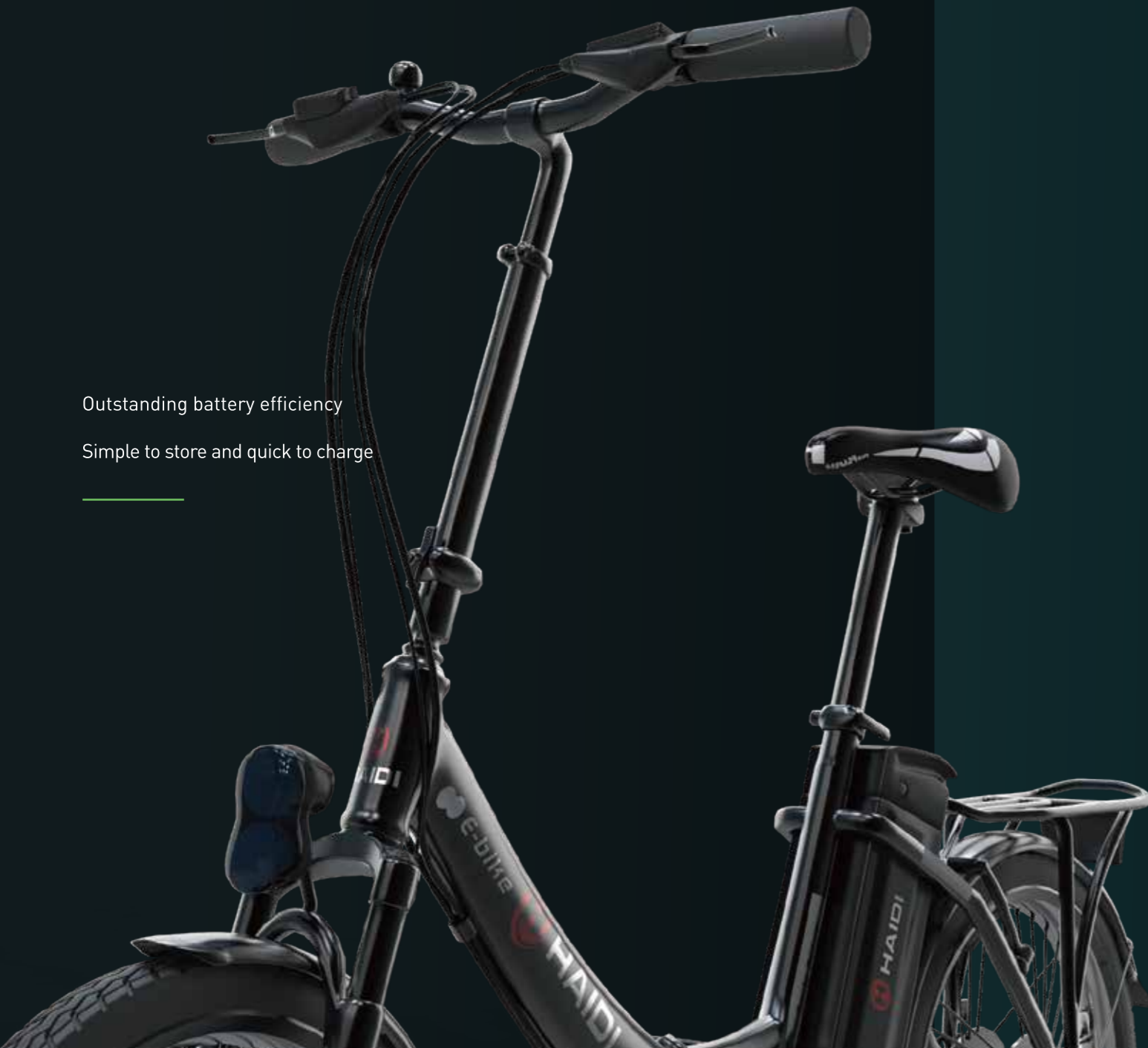

Electric Bike Battery

Haidi adopt high-quality 18650 lithium ion battery cell, combined with high-strength BMS, to present all users with excellent battery performance.

- The charge and discharge cycle of our batteries go up to 1000 times;
- The lifespans up to 5 years;
- 3-5hours fast charge;
- The driving range up to 30 kilometers.

Battery Safe Lock
Lock the battery on the frame



Power Switch
Turn on and off the battery power.



USB Charge Socket
5V/1A Output Can be used to charge cell phone



Discharge Socket
Discharge cable connect to bike controller power cable.



Battery Install Plate
The battery and the mounting plate will be mounted together before shipment. The user can take off the battery by key firstly, and then screw the plate on bike frame, and mount the battery on the plate finally.

Battery Power Indicator
Press the ⏻ button the light will turn on.

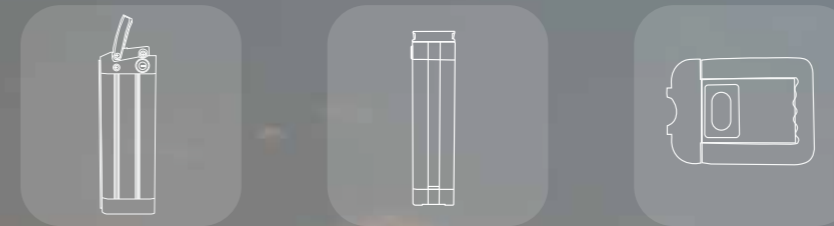
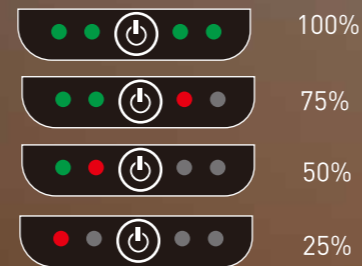

Electrical Parameters	
Capacity	10Ah / 15Ah / 17.5Ah / 21Ah
Voltage	24V / 36V / 48V / 51.2V
Combination	7S6P / 10S4P / 10S6P / 13S5P / 14P5S
Built-in Battery cell	18650 Li-Battery Cell x 70pcs (max)
Charging Temperature	0-45°C
Discharging Temperature	-20-60°C
Dimension	365mm x 90mm x 110mm(LxWxH)
Weight	About 3.5-4.5Kg

Note: Custom battery design and production are supported



FA
D

*MORE POWER
MORE EFFICIENCY
MORE TO LOVE*



ELECTRIC MOTORCYCLE BATTERY



ELECTRIC MOTORCYCLE BATTERY

MORE POWER, MORE EFFICIENCY, MORE TO LOVE

The batteries of AGM or Gel of the motorcycles and electric mopeds lose autonomy with the passage of time and it is not possible to regenerate the old ones and obtain an optimal operation. At this point it is necessary to buy new batteries, we offer you the possibility of purchasing a customized lithium battery for your motorcycle and convert your electric motorcycle from AGM to Lithium-Ion.



Parameter	HDEM 48V10Ah	HDEM 48V12Ah	HDEM 48V26Ah	HDEM 48V29Ah	HDEM 60V10Ah	HDEM 60V23Ah
Normal Voltage	48V			60V		
Capacity	10Ah	12Ah	26Ah	29Ah	10Ah	23Ah
Typical Energy (Wh)	480Wh	576Wh	1248Wh	1392Wh	600Wh	1380Wh
Combinations	18S1P	16S1P	15S9P	14S10P	20S1P	18S8P
Battery Materials	Li-ion					
Max. Pulse Discharge	100A(20 Sec.)					
Max. Cont. Discharge	60A					
Battery Weight	9.5Kg	10.5Kg	10Kg	10.2Kg	11Kg	10.2Kg
Battery Dimensions (L*W*H)	364 x 212 x 85 mm			430 x 212 x 85 mm		

Note: We also support customized battery design and production.

Golf Trolley Batteries

Lithium batteries are overwhelmingly being chosen to use for golf trolleys and golf buggies instead of the traditional Sealed Lead Acid batteries. They have longer lifespans which make them much more cost effective in the long term. Haidi's lithium batteries are super lightweight, extremely reliable and their compact sizes require much easier transportation.

Features & Benefits:

- Up to 10 times longer lifespan than SLA battery
- Smaller size & extremely lightweight
- Faster Charging-50% quicker than SLA battery
- Superior safety-unique design without risk of explosion
- Wider range- LiFePO4 batteries & Lithium-ion batteries
- 5V USB Port for mobile devices(optional)

Golf Trolley Battery

Part No.	V	Ah	Wh	Dimension(mm)			Weight(kg)	Terminal
				Length	Width	Height		
HG 12-12	12.8	12	153.6	152	99	96	1.5	M2+Anderson Connector
HG 12-16	12.8	16	204.8	168	128	75	2.2	T-Bar +Anderson Connector
HG 12-18	12.8	18	230.4	181	77	168	2.6	T-Bar +Anderson Connector
HG 12-20	12.8	20	256	181	77	168	2.8	T-Bar +Anderson Connector
HG 12-22	12.8	22	281.6	168	175	125	3.0	T-Bar +Anderson Connector

The new Haidi Lithium batteries come in two different sizes that will do 18 holes and 36 holes on one charge plus they're lighter and smaller so your trolley will be easier to handle.

This battery is lightweight compared to an equivalent lead-acid battery and can be fully charged within 5 hours and has a five times longer lifespan to reduce the overall cost per round. With the battery comes a neoprene battery bag with carry handle and comes with lithium battery charger which protects and prevents overcharging. For peace of mind and added value, the battery comes with a 5-year warranty. Golfers can simply change and upgrade your battery for one of these 18 or 36 hole modern batteries and they come with a 5 year warranty.



Advantage Features

- ULTRA SAFETY
- PREMIUM QUALITY
- PROLONGED CYCLE LIFE
- ULTRA-LIGHT
- CONSUMPTION
- HIGH ENERGY DENSITY

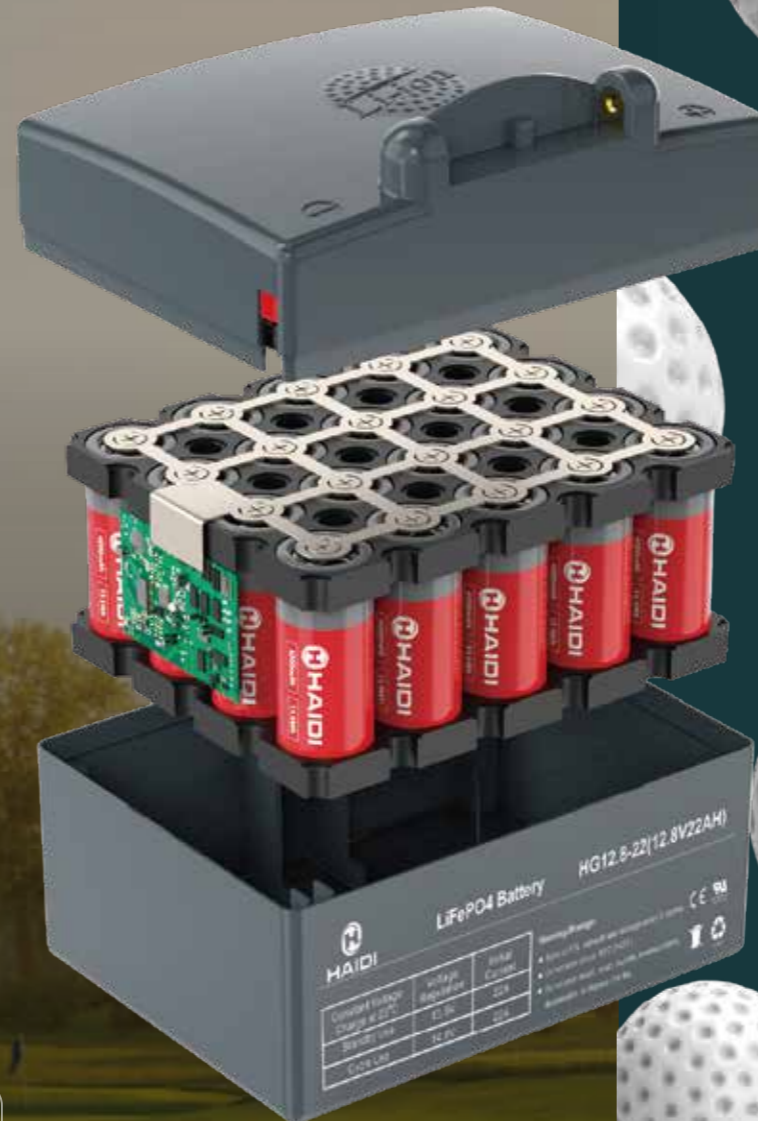

Sightseeing Vehicle Battery Solution

LITHIUM IRON PHOSPHATE TECHNOLOGY

The competitive edge for your business



KEY ADVANTAGES OF HAIDI BATTERIES



High Safety

Haidi LiFePO₄ Batteries have passed through all tests of crashing, squeezing, nail penetration and flaming. The high safety has been ensured.



Long Cycle Life

Haidi batteries can remain 80% capacity after 4000 cycles. The design life span of our batteries are upto 15 years.



High Efficiency

High charging efficiency >98%, our batteries can be fully charged in one hour.



Wide Working Temperature Range

Haidi batteries are suitable for various working environment. The batteries can be discharge from -40°C to 60°C.



Free Maintenance

Haidi LiFePO₄ batteries adopt a fully enclosed design, which does not need any manual maintenance and periodic filling of electrolyte.

Sightseeing Vehicle Battery Solution

EFFICIENCY

Greater efficiency than lead-acid models, with no power loss

MAINTENANCE

Zero maintenance, 100% worry-free

CHARGING TIME

Two times faster charging than lead-acid batteries when equipped with the Haidi SuperCharger

BATTERY HEALTH

Charge anytime, for any length of time

Model No	HS48150 (48V150Ah)	HS48180 (48V180Ah)	HS48200 (48V200Ah)	HS72200 (72V200Ah)	HS72400 (72V400Ah)	HS96400 (96V400Ah)	HS96504 (96V504Ah)
Nominal Voltage	48V	48V	48V	73.6V	73.6V	96V	96V
Nominal Capacity	150Ah	180Ah	200Ah	200Ah	400Ah	400Ah	504
Energy	7.2kWh	8.64kWh	9.6kWh	14.72kWh	29.44kWh	38.4kWh	48kWh
Charging Voltage	54.75V	54.75V	54.75V	83.95V	83.95V	109.5V	109.5V
Charge Current	≤75A	≤90A	≤100A	≤100A	≤100A	≤100A	≤100A
Discharge Current	200A	200A	200A	200A	200A	400A	500A
Peak Discharge Current	450A	540A	600A	600A	1200A	1200A	1500A
End-Of Voltage	37.5V	37.5V	37.5V	57.5V	57.5V	75V	75V
Cycle Life	>4000 time (80% DOD)						
BMS Communication	CANBUS/MODBUS/RS485/RS232						
SoC Display	LED/LCD display						
Charging Temperature	0 ~ 45°C						
Discharge Temperature	-40 ~ 60°C						
Storage Temperature	-20 ~ 60°C						
Shell Material	Metal						
Battery Weight	68kg	75kg	87kg	150kg	290kg	360kg	420kg
Battery Dimension(mm)	840*300*270	840*300*300	840*300*320	1170*320*280	1140*320*280*2	990*320*280*3	1640*320*280

DATA SHEETS



Front View

Haidi Battery Monitor is designed to measure a battery's state of charge (SoC). It measures voltage, current, and capacity in real-time. The monitor will show both power consumption as well as power replenishment. The active back-lite makes it easy to read and has a low power draw.

CELL SELECTION

Proven safest chemistry
 Longest life in its class
 Highest capacity in its class
 Haidi LFP technology
 UN38.3; UL 1642; IEC 62133

BATTERY DESIGN

Easy replacement for lead-acid
 Robust case, IP67 rating
 Automotive-grade safety protection
 Current sensor, fuse, temp. sensor
 Validated charger compatibility

ELECTRONICS

LED SoC display
 Smart battery management system
 Microprocessor-based controls
 CAN-communications



HD72-400 28.8KWh LFP Battery



HD72-200 14.4KWh LFP Battery



HD96-504 48.4KWh LFP Battery



HD96-400 38.4KWh LFP Battery

AGV LITHIUM ION SMART BATTERY SYSTEM

Advanced Lithium Battery Solutions for Next Generation AGVs

Li-THIUM

- + Battery Management System + CANbus capable
- + Heating function optional
- + Integrated safety features
- + 40% reduction in TCO
- + 20% boost in productivity
- + 50% higher run time
- + Increased battery lifespan (over 4x longer life)
- + Opportunity charge preferred
- + Battery Management System + CANbus capable
- + Heating function optional
- + Integrated safety features
- + 40% reduction in TCO
- + 20% boost in productivity
- + 50% higher run time
- + Increased battery lifespan (over 4x longer life)
- + Opportunity charge preferred



Advantage Features

Haidi's lithium solution for AGV is a comprehensive, self-managed battery system designed to meet the cost, performance, efficiency, and durability requirements of the rugged warehouse environment. It includes application-specific cell chemistry, charge/discharge management, and advanced safety features such as thermal, short circuit, over voltage, and under voltage protection.



Electrical Parameters		
Nominal Voltage	24V	48V
Rated Capacity	50Ah	50Ah
Energy	1200Wh	2400Wh
Charge input voltage	29.4±0.2V	58.4±0.2V
Charge current	≤25A	≤25A
Self Discharge	2% per Month	
Inner resistance	≤20mΩ	
Total Weight(kg)	14kg	28kg
Size (L*W*H)	260*180*254mm	350*300*180mm
Humidity	5%≤RH≤85%	
Continuous discharge current	25A	25A
Discharge cut-off voltage	19.6V	39V
Cycle Life	>3000cycles	
Discharge Temperature	0°C ~ +45°C	
Charge Temperature	-20°C ~ +60°C	
Storage Temperature	0°C ~ 40°C	

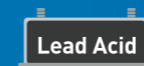

Purchases Over 5 Years	Maintenance	Battery Cost	Installation	Shipping	Electricity Waste
	N/A	⌘ X5	⌘ X2	⌘	N/A
	N/A	N/A	N/A	N/A	N/A
	N/A	N/A	N/A	N/A	N/A
	⌘ X3	⌘ X4	⌘ X2	⌘	⌘ X3
	⌘ X3	⌘ X4	⌘ X2	⌘	⌘ X3
	⌘ X3	⌘ X4	⌘ X2	⌘	⌘ X3



Maintenance Free



Custom Engineered



Environmentally Safe



Plug-and-play Compatibility



Longer Run Time



1-3 Year ROI

ONE CHARGE, ONE COMPLETE CLEAN

FLOOR SCRUBBER BATTERY

Haidi features all the benefits of lithium batteries – longer life, no maintenance, faster charging – with even more intelligent features built-in. From its superior battery design to its one-of-a-kind BMS and intuitive software, Haidi 24V batteries offer exclusive advantages you won't find in competitive products. Making it an exceptional return on your investment for years to come.

LI THIU
technology



FLOOR SCRUBBER

LITHIUM FEATURES AND BENEFITS



LIGHTWEIGHT

Lithium batteries are typically half the weight of lead-acid batteries.



MAINTENANCE-FREE

Haidi lithium batteries are maintenance free - no watering; no corrosion.



HIGHLY EFFICIENT

Fast recharge time and a 99% efficient recharge process, which means less wasted electricity.



PARTIAL STATE OF CHARGE (PSOC) TOLERANT

If operated in PSOC there is no damage. This is one of the leading causes of early failure in lead-acid batteries.



LONGER LIFE

Up to 10X longer life span compared to lead-acid batteries



SAFETY

Inherently safe chemistry. BMS provides extra protection.



MORE USEABLE CAPACITY

A 25-50% higher capacity than lead-acid batteries with full power available throughout discharge.



LOWER TOTAL COST OF OWNERSHIP

Changing batteries less often means fewer replacement and labor costs.

Compared to lead-acid and other lithium batteries, lithium iron phosphate batteries offer significant advantages, including improved discharge and charge efficiency, longer life span and the ability to deep cycle while maintaining power. LiFePO4 batteries often come with a higher price tag, but a much better cost over life of the product. No maintenance and super long life makes them a worthwhile investment and a smart longterm solution.

FUNCTIONAL SPECIFICATIONS

Nominal Voltage	25.6
Cell Chemistry	LiFePO4
Cell Type	Prismatic
Ampere-hour Capacity	60Ah
Watt-hour Capacity	1,536kWh
Specific Energy	128Wh/kg
Charge Efficiency	99%
Impedance [50% SOC, 1kHz]	<100mΩ
Cycles @ 80% DOD	>6000



Products Angle

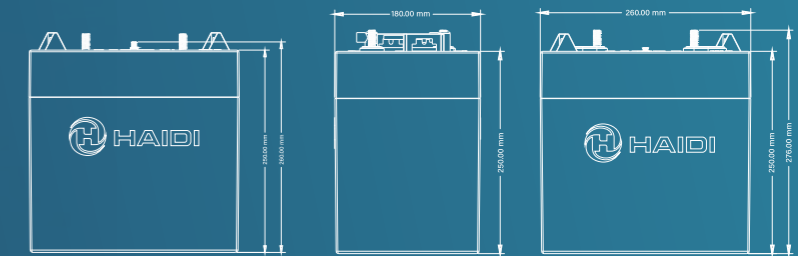

HAI DI FORKLIFT LITHIUM BATTERIES



SMART. ECONOMIC. TOUGH.

More flexibility due to decentralized charging stations.

Longer operating times and higher productivity due to fast and opportunity charging.

The Haidi battery system is absolutely maintenance-free

No need for battery change-outs and additional spare batteries.

No need for centralized battery rooms with expensive ventilation systems and fire doors.

Very low operating costs combined with significant savings in electricity and water costs.

TCO (Total Costs of Ownership) - significantly reduced total lifetime costs.

Engineered for Peak Performance

APPLICATION ADVANTAGES OF HAIDI FORKLIFT LITHIUM BATTERIES

SAVE ON LABOR

No maintenance, no battery changes, and one-hour charge time. Manage company growth with same number of fleet equipment and personnel.

MORE EFFICIENCY

In 2-3 shift applications, one Haidi lithium battery is sufficient when it could take 2 or 3 lead acid batteries to get the same work done.

PROMOTE GREENER FACILITY & WORKER SAFETY

Less energy consumption and workers are no longer exposed to acid and out-gasses. You can also eliminate dangerous battery changes.

MOVE MORE MATERIAL PER SHIFT

Lithium's voltage stays steady under load throughout the entire shift. No voltage drop or performance degradation at the end of a shift or work cycle.

WORRY LESS WITH ACCURATE DATA

Onboard monitor provides operator with accurate current/voltage measurements and state-of-charge.

EMPLOY CONFIDENCE

Haidi cells boast UL-recognition, durable design, fail safe chemistry, patented cell design, and telematics for total protection.



25.6V100Ah

51.2V450Ah

51.2V460Ah

80V450Ah

80V600Ah

Part Number	Voltage (V)	Capacity (Ah)	Energy (KWh)	Diameter (mm)	Weight (Kg)
HD24100(24V100AH)	24	100	2.56	624*212*627	63.00
HD36100(36V100AH)	36	100	3.84	520*255*300	85.00
HD48300(48V300AH)	48	300	15.36	830*630*627	330.0
HD48450(48V450AH)	48	450	23.04	1223*427*784	370.0
HD48460(48V460AH)	48	460	23.55	1223*355*784	390.0
HD76450(76V450AH)	76	450	34.56	1625*590*520	410.0
HD76600(76V600AH)	76	600	46.08	1140*673*615	550.0
HD80450(80V450AH)	80	450	36.00	1028*855*784	450.0
HD80600(80V600AH)	80	600	48.00	1028*999*784	590.0

An aerial photograph of a boat moving through the ocean, leaving a large, circular wake. The water is a deep blue, and the wake is a lighter, frothy white. The boat is visible in the lower right quadrant of the wake.

AQUA SERIES

ADVANCED MARINE BATTERIES
FOR CLEAN BOATING

More power, more energy, more silence and more convenience

AQUA SERIES ADVANCED MARINE BATTERIES FOR CLEAN BOATING

All AQUA series batteries offer abundant power in a small footprint. It's versatile and compact enough to be used in many marine applications including smaller boats with lower battery requirements, boats that require two of the same batteries and boats with electrical systems designed for just one battery.

Intelligent battery management system (BMS)

The BMS monitors and protects batteries against overcharging, overcurrent, deep discharge, short-circuit and overheating. The battery has comprehensive safety features, and each safety-relevant component is duplicated with a backup component. In addition to these safety features, the BMS safeguards the battery's life expectancy with balancing and deep-sleep functionality.

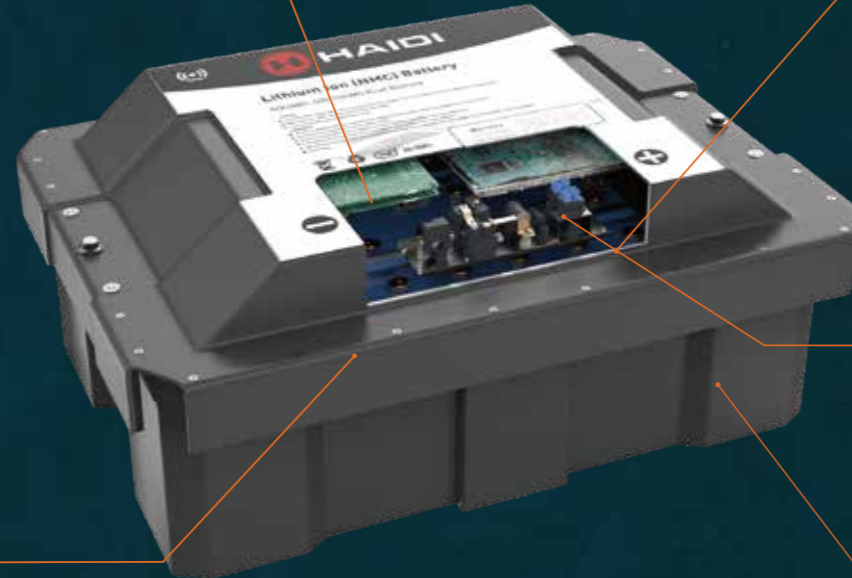

Safe and easy to transport

Thanks to the high energy density, the volume and weight of lithium batteries are more than 70% lower than comparable AGM or lead-gel batteries. This makes our low-voltage batteries simple to handle and light to carry. On top of that, AQUA batteries can be switched on and off, allowing them to be safely transported and installed and protecting them against unintentional discharge.

Safety of AQUA lithium batteries

Besides performance, safety plays an important role for lithium batteries in case of marine application. In our view, four factors need to be considered in order to ensure that safe really means safe driving:

1. Safe cell packaging: Haidi uses only individually welded safety cells: either cylindrical or assembled into modules and equipped with multiple safety mechanisms.
2. Haidi only uses cells and modules produced by ourselves.
3. Battery management system (BMS) with redundant safety features: Unlike lead-based batteries, lithium batteries always need a BMS to perform balancing and safety functions. If electronic components of the BMS fail it can itself become a safety problem for the battery. That's why there is hardware backup for all safety-relevant components in Haidi batteries.
4. Waterproof to IP67: Water in lithium batteries can lead to various problems such as corrosion of the BMS hardware or the creation of electrolytic gas. Lithium batteries on board a boat shall, therefore, be waterproof.

By delivering more power, more energy, more silence and more convenience, Haidi honors our commitment to improving customers' boating experiences and advancing marine electric mobility every year.

High-quality safety cells

Several hardware mechanisms in every single cell provide additional safety. State-of-the-art fully automatic cell production lines and quality management system of Haidi guarantee the high quality and safety of cells. The cells are certified by accredited laboratories.

System communications

The battery electronics continuously communicate all the details of the battery status to the onboard computer.

Completely waterproof

Waterproof housing (IP67): While battery immersion should be avoided, all AQUA batteries are, without exception, completely waterproof. The waterproof characteristics of each battery are individually tested prior to delivery. Waterproof connections: whether connected or not, all cable connectors are completely waterproof to IP67.



Advanced Marine Batteries For Clean Boating

Lithium is the logical choice for marine applications where you need a longer run time and reliability. The MAB series for marine application is lithium battery with more power, less weight and up to 10x longer life than its lead-acid counterparts. MAB series lithium batteries provide more energy for high consumption than traditional lead-acid batteries. Lead-acid batteries also need to be maintained. If they are not maintained properly, their life span is shortened. Because lithium batteries require no active maintenance, a one-time purchase guarantees better lifetime value. By delivering more power, more energy, more silence and more convenience, Haidi honors our commitment to improving customers' boating experiences and advancing marine electric mobility.

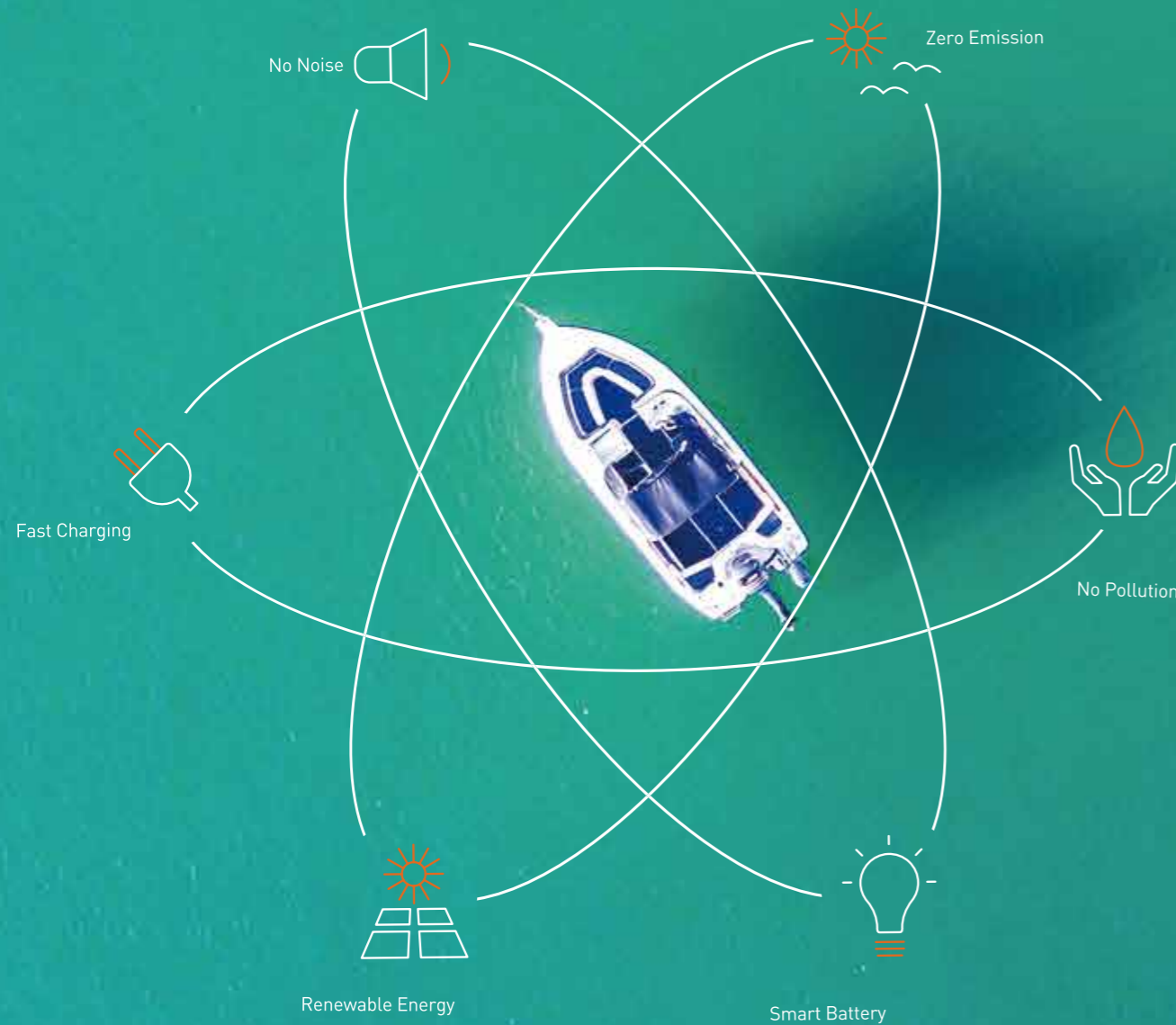

Safe, powerful and easy to use – Power batteries are the ultimate energy source for Cruise motors or house loads

High-capacity batteries with technology by Haidi deliver more range and even longer runtimes, with 31% more capacity in the same footprint.

AQUA96-270 26kWh Boat Battery



Specifications	
Useable energy	25,920Wh
Nominal voltage	96 V
Weight	145 kg (319 lbs)
Energy density (weight)	178 Wh/kg
Maximum discharge rate	375 A (4,500W at nominal voltage)
Dimensions(L*W*H)	960*330*430mm
Battery chemistry	Li NMC
Cycle lifetime	800 cycles at 100% depth of discharge at 25 °C results in approx. 25% capacity loss
Annual capacity loss	<3%
Max. connections	26S104P

AQUA80-400 32kWh Boat Battery



Specifications	
Useable energy	32,000 Wh
Nominal voltage	80 V
Weight	248 kg (545.6 lbs)
Energy density (weight)	129 Wh/kg
Maximum discharge rate	400 A (4,500W at nominal voltage)
Dimensions(L*W*H)	750*600*360mm
Battery chemistry	Li NMC
Cycle lifetime	800 cycles at 100% depth of discharge at 25 °C results in approx. 25% capacity loss
Annual capacity loss	<3%
Max. connections	154P22S

AQUA72-200 14kWh Boat Battery



Specifications	
Useable energy	14,400 Wh
Nominal voltage	72 V
Weight	120 kg (264 lbs)
Energy density (weight)	120Wh/kg
Maximum discharge rate	400 A (4,500W at nominal voltage)
Dimensions(L*W*H)	720*500*250mm
Battery chemistry	Li NMC
Cycle lifetime	800 cycles at 100% depth of discharge at 25 °C results in approx. 25% capacity loss
Annual capacity loss	<3%
Max. connections	90P20S

service.

Delivering **Advanced** lithium battery solution across a **worldwide** network

Haidi Energy has corporate offices across the globe with distributors and regional offices in more than twenty countries. Our global network means that wherever you do business, Haidi is there and ready to assist. Our global network is one of the key factors of our leadership position and a promise to deliver innovative lithium battery solutions and excellent service close to our clients, knowing their industry challenges and speaking their languages.

Our Service

Our global presence spans over five continents to support your business requirements at the time and place that meets your business needs.



Think big!

